

## PAB01 Smart Energy In Wall Meter

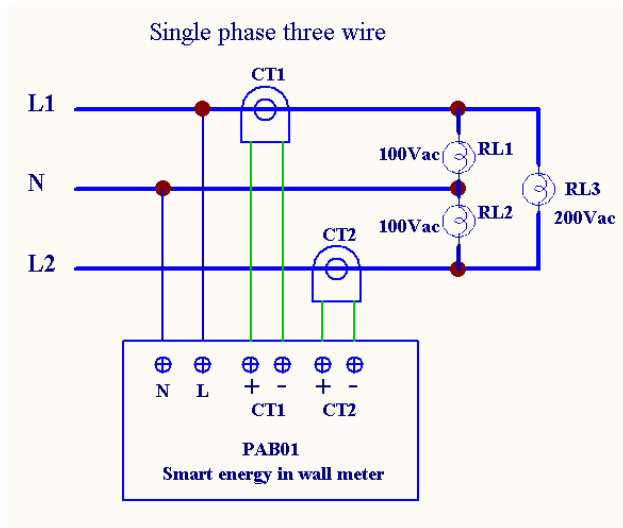

**Fig 1. Assembling**

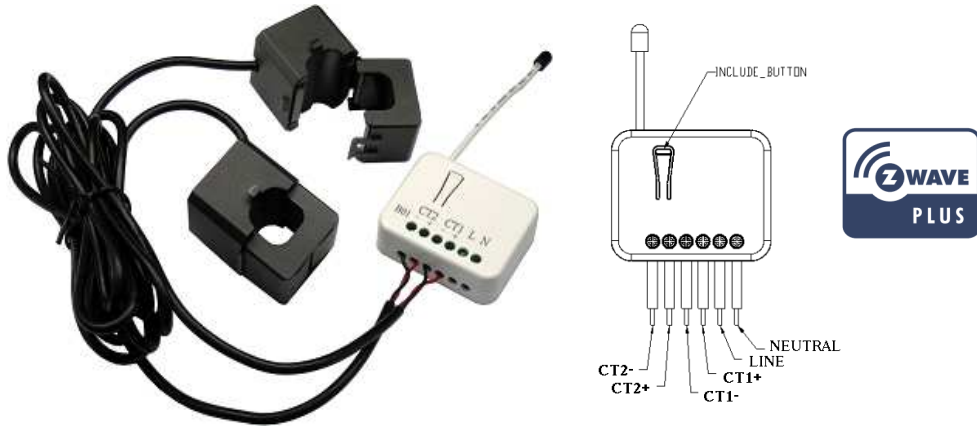
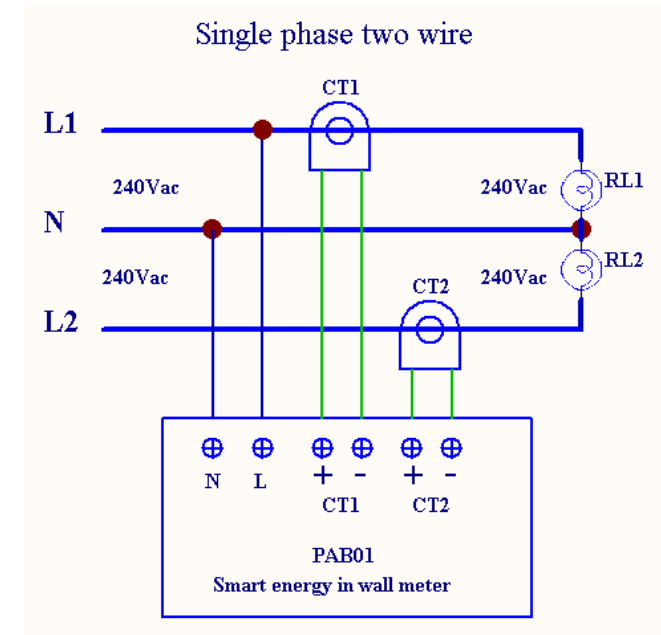

**Fig 2. Assembling**

This dual meter module is a transceiver which is a Z-Wave™ enabled device and is fully compatible with any Z-Wave™ enabled network. This product can be included and operated in any Z-Wave network with other Z-Wave certified devices from other manufacturers and/or other applications. And it can act as repeaters within the network regardless of vendor to increase reliability of the network.

Mini size design let the module can easily hide itself into the electricity distribution box and that will be good for the house decoration. This dual meter module is able to detect Instant power wattage (13800W/230Vac)(60 Amperes) of connected light or appliances.

### Adding to Z-Wave™ Network

In the front casing, there is an on/off button with LED indicator below which is used to carry out inclusion, exclusion, reset or association. After being excluded, its LED flashes on and off alternately and repeatedly at 2-second intervals. It implies that it has not been assigned a node ID and cannot work with Z-Wave enabled devices.

## Auto Inclusion

The function of auto inclusion will be executed as long as the meter does not have Node ID and just connect the meter to main power. When first power is applied, its LED flashes on and off alternately and repeatedly at 0.5 second intervals. It implies that it is in leaning mode now.

**Note:** Auto inclusion timeout is 2 minute during which the node information of explore frame will be emitted once every 5 seconds. Unlike “inclusion” function as shown in the table below, the execution of auto inclusion is free from pressing the Include button on the meter.

The table below lists an operation summary of basic Z-Wave functions. Please refer to the instructions for your Z-Wave™ Certificated Primary Controller to access the Setup function, and to include/exclude/associate devices

Function	Description	LED Indication
No node ID	The Z-Wave Controller does not allocate a node ID to the meter.	LED 2-second on, 2-second off
Inclusion	1. Put your Z-Wave controller into inclusion mode by following the instructions provided by the controller manufacturer.	One press one flash LED
	2. Pressing Include button three times within 2 seconds will enter inclusion mode.	
Exclusion	1. Put your Z-Wave controller into exclusion mode by following the instructions provided by the controller manufacturer.	One press one flash LED
	2. Pressing Include button three times within 2 seconds will enter exclusion mode.	
	3. Node ID has been excluded.	LED 0.5s On, 0.5s Off (Enter auto inclusion)
Reset	1. Pressing INCLUDE_BUTTON three times within 2 seconds will enter inclusion mode.	Use this procedure only in the event that the primary controller is lost or otherwise

	2. Within 1 second, press Include button again for 5 seconds.	inoperable.
	3. IDs are excluded.	LED 0.5s On, 0.5s Off (Enter auto inclusion)
Association	1. The PAB01 is an always listening Z-Wave device, so associations be added or removed by a controller at any time. Or If your controller requires to have the PAB01 send a 'node information frame' or NIF for associations, pressing the On/Off button three times within 2 seconds will cause the PAB01 to send its NIF.	LED One press one flash
	2. There are 3 groups for the meter	
※ Adding a node ID allocated by Z-Wave Controller means inclusion. Removing a node ID allocated by Z-Wave Controller means exclusion. ※ Failed or success in including/excluding the node ID can be viewed from the Z-Wave Controller.		

## LED Indication

To distinguish what mode the meter is in, view from the LED for identification.

State Type	LED Indication
No node ID	Under normal operation, when the meter has not been allocated a node ID, the LED flashes on and off alternately at 2 seconds intervals.
Learning	When PAB01 is in learning mode, LED flashes on and off alternately and repeatedly at 0.5 second intervals.

## Choosing a Suitable Location

1. Do not locate the meter facing direct sunlight, humid or dusty place.
2. The suitable ambient temperature for the Switch is 0℃~40℃.
3. Do not locate the meter where exists combustible substances or any source of heat, e.g. fires, radiators, boiler etc.
4. After putting it into use, the body of meter will become a little bit hot of which phenomenon is normal.

## Installation

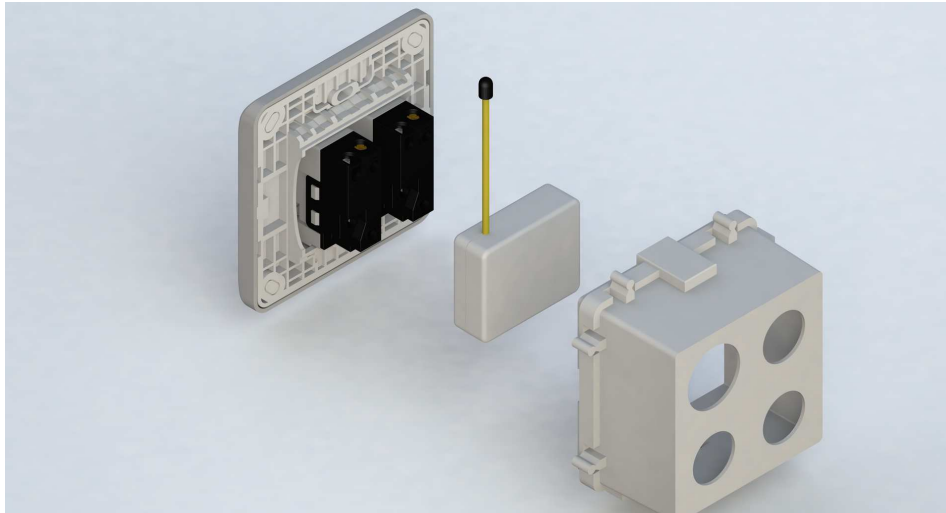

1. Put the meter into a wall box and connect the AC power wire L,N to PAB01 connector L, N.
2. The black wire of current sensor, CT1 or CT2, should be connected to the negative terminal of PAB01,CT1- or CT2-. Another wire should be connected to the plus terminal of PAB01,CT1+ or CT1+.
3. There is a clasp on the side of the current sensor, it can lock or unlock the clamp. It is convenient to circle the already connected cable.

## Programming

### 1. Z-Wave's Groups (Association Command Class Version 2)

The meter can be set to send reports to associated Z-Wave devices. It supports 3 association groups which every group has one node support. Group1~Group3 support METER\_REPORT\_COMMAND\_V3

For group 1, the Switch will report : (1) Instant Power Consumption (Watt) read from CT1 , (2) Accumulated Power Consumption (KWh) read from CT1.

For group 2, the Switch will report : (1) Instant Power Consumption (Watt) read from

CT2 , (2) Accumulated Power Consumption (KWh) read from CT2.

For group 3, the Switch will report (1) The sum of instant Power Consumption (Watt) read from CT1 and CT2 (2) The sum of accumulated Power Consumption (KWh) read from CT1 and CT2.

### 2-1 Auto report to Grouping 1 ~3 (Maximum 1 node per Group)

#### 2-1-1 Instant Power Consumption vary over 5% report

When the instant power consumption read from CT1 or CT2 vary over 5%, it will send Meter report to the node of Group

Meter Report Command: <b>[Command Class Meter , Meter Report , Rate Type = 0x01 , Meter Type = 0x0q , Precision = 1 , Scale = 0x02 , Size = 4 , Meter Value (W)]</b>
--

#### 2-2 Response to Meter Get Command

The Switch will report : (1) instant Power Consumption (Watt) , (2) accumulated power consumption(KWH) , (3) AC input Voltage (V) , (4) AC load current ( I ) , (5) load power factor (PF) to Z-Wave Controller after receive the Meter Get Command from Z-Wave Controller.

#### 2-2-1 Instant Power Consumption (Watt)

When receiving Meter Get Command, it will report Meter Report Command to the node asked.

Meter Get Command: <b>[Command Class Meter, Meter Get, Scale =0x02(W)]</b>
--

Meter Report Command: <b>[Command Class Meter , Meter Report , Rate Type = 0x01 , Meter Type = 0x01 , Precision = 1 , Scale = 0x02 , Size = 4 , Meter Value (W) ]</b>
---

Example:

Meter Value 1 = 0x00 (W)

Meter Value 2 = 0x00 (W)

Meter Value 3 = 0x03 (W)

Meter Value 4 = 0xEA (W)

Meter(W) = Meter Value 3 \*256 + Meter Value 4 = 100.2W

#### 2-2-2 Accumulated Power Consumption (KW/h)

When receiving Meter Get Command, it will report Meter Report Command to

the node asked.

Meter Get Command: [**Command Class Meter, Meter Get, Scale = 0x00 KW/h**]

Meter Report Command: [**Command Class Meter , Meter Report , Rate Type = 0x01 , Meter Type =0x01 , Precision = 2 , Scale = 0x00 , Size = 4 , Meter Value (KW/h)4**]

Example:

Scale = 0x00 (KW/h)

Precision = 2

Size = 4 Bytes (KW/h)

Meter Value 1 = 0x00(KW/h)

Meter Value 2 = 0x01(KW/h)

Meter Value 3 = 0x38(KW/h)

Meter Value 4 = 0xA3(KW/h)

Accumulated power consumption (KW/h) = (Meter Value 2\*65536) + (Meter Value 3\*256) + (Meter Value 4) = 800.35 (KW/h)

### 2-2-3 Clearing accumulated power consumption

Whenever re-start counting the accumulated power consumption is needed, you can use Meter Reset Command to clear it.

Meter Reset Command: [**Command Class Meter, Meter Reset**]

### 2-2-4 AC input Voltage (V)

When receiving Meter Get Command, it will report Meter Report Command to the node asked.

Meter Get Command: [**Command Class Meter, Meter Get, Scale =0x04(V)**]

[**Command Class Meter , Meter Report , Rate Type = 0x01 , Meter Type = 0x01 , Precision = 1 , Scale = 0x04 , Size = 2 , Meter Value(V) ]**

Example:

Scale = 0x04 (V)

Precision = 1

Size = 2 (2 Bytes of V)

Meter Value 1 = 0x09(V)

Meter Value 2 = 0x01(V)

AC load Voltage = (Meter Value 1\*256) +(Meter Value 2)= 230.5 (V)

### 2-2-5 AC load current ( I )

When receiving Meter Get Command, it will report Meter Report Command to the node asked.

Meter Get Command: [**Command Class Meter, Meter Get, Scale =0x05(I)**]

**Meter Report Command:**

[**Command Class Meter , Meter Report , Rate Type = 0x01 , Meter Type = 0x01 , Precision = 2 , Scale = 0x05 , Size = 2 , Meter Value(I)**]

Example:

Scale = 0x05 (I)

Precision = 2

Size = 2 (2 Bytes of I)

Meter Value 1 = 0x01(I)

Meter Value 2 = 0x21(I)

AC load current = (Meter Value 1\*256) +(Meter Value 2)= 2.89 (A)

### 2-2-6 load power factor (PF)

When receiving Meter Get Command, it will report Meter Report Command to the node asked.

If the value of configuration parameter 3 is 1, it will report the power factor of CT1, but not the sum of PF of CT1 and CT2.

Meter Get Command: [**Command Class Meter, Meter Get, Scale =0x06(PF)**]

**Meter Report Command:**

[**Command Class Meter , Meter Report , Rate Type = 0x01 , Meter Type = 0x01 , Precision = 2 , Scale = 0x06 , Size = 1 Bytes , Meter Value(PF)**]

Example:

Scale = 0x06 (PF)

Precision = 2

Size = 1 (1 Byte of PF)

Meter Value 1 = 0x63(PF) (It means that the load power factor is 0.99)

**2-3 Multi Channel Command Class Version 4**

PAB01 also support muti channel command class(version 4) , which include METER\_SUPPORTED\_GET, METER\_RESET, METER\_GET.

You may get report from 3 endpoint of PAB01

**2-3-1 METER\_SUPPORTED\_GET :**

This command is to ask the endpoint of PAB01 what kind of meter data can be reported.

The example show how to get the meter report type

COMMAND_CLASS_MULTI_CHANNEL	
MULTI_CHANNEL_CMD_ENCAP	
Source End Point = 0x01	(this is the endpoint of command inquirer here we assume endpoint is 1 , if the inquirer doesn't support multi Channel this value will be 0)
(Bit Address+Destination End Point = 0x03)	(Bit Address =0 ; Destination End Point range1~3)
Command Class = 0x32	( Command_Class_Meter_V3 = 0x32)
Command =0x03	(Meter_Supported_Get = 0x03)

Below is the example show PAB01 report to last command

COMMAND_CLASS_MULTI_CHANNEL	
MULTI_CHANNEL_CMD_ENCAP	

Source End Point = 0x03	
(Bit Address+Destination End Point = 0x01)	
Command Class = 0x32	(Command_Class_Meter_V3 = 0x32)
Command =0x04	(Meter_Supported_Report = 0x04)
Parameter 1 = 0x81	(Meter Reset =1 , Meter Type=0x01)
Parameter 2 = 0x75	(Scale Supported = KWh+W+V+I+Power Factor = 0x75)

**2-3-4 METER\_RESET**

This command is to reset the Accumulated Power Consumption (KWh) to 0

The example show how to reset the KWh

COMMAND_CLASS_MULTI_CHANNEL	
MULTI_CHANNEL_CMD_ENCAP	
Source End Point = 0x03	(this is the endpoint of command inquirer, here we assume endpoint is 3 , if the inquirer doesn't support multi Channel this value will be 0)
(Bit Address+Destination End Point = 0x01)	(Bit Address =0 ; Destination End Point range1~3)
Command Class = 0x32	( Command_Class_Meter_V3 = 0x32)
Command =0x05	( Meter_Reset = 0x05)

**2-3-5 METER\_GET :**

Using meter get command to get the KWH,W,V,I,PF from endpoint of PAB01

### 2-3-5-1 Get KWH from endpoint

Meter\_GET example:

COMMAND_CLASS_MULTI_CHANNEL	
MULTI_CHANNEL_CMD_ENCAP	
Source End Point = 0x05	(this is the endpoint of command inquirer, here we assume endpoint is 5 · if the inquirer doesn't support multi Channel this value will be 0)
(Bit Address+Destination End Point = 0x03)	(Bit Address =0 ; Destination End Point range1~3)
Command Class = 0x32	( Command_Class_Meter_V3 = 0x32)
Command =0x01	(Meter_Get = 0x01)
Parameter 1 = 0x00	(Scale = KWH = 0x00)

Accumulated power consumption (KWH) Report example :

COMMAND_CLASS_MULTI_CHANNEL	
MULTI_CHANNEL_CMD_ENCAP	
Source End Point = 0x03	(Meter report = Endpoint3)
(Bit Address+Destination End Point = 0x05)	(Bit Address =0 ; Destination End Point = command inquirer's Endpoint value)
Command Class = 0x32	(Command_Class_Meter_V3 = 0x32)

Command =0x02	(Meter_Report = 0x02)
Parameter 1 = 0x21	(Scale Bit2 = 0 · Rate Type = 0x01 , Meter Type=0x01)
Parameter 2 = 0x44	(Precision = 2 · Scale Bit1Bit0 = 0 · Size = 4)
Parameter 3 = 0x00	Accumulated Power Consumption = 0x000005FD = 15.33 KWh
Parameter 4 = 0x00	
Parameter 5 = 0x05	
Parameter 6 = 0xFD	

### 2-3-5-2 Get Instant Power Consumption (Watt) from endpoint

METER\_GET example :

COMMAND_CLASS_MULTI_CHANNEL	
MULTI_CHANNEL_CMD_ENCAP	
Source End Point = 0x05	(this is the endpoint of command inquirer, here we assume endpoint is 5 · if the inquirer doesn't support multi Channel this value will be 0)
(Bit Address+Destination End Point = 0x03)	(Bit Address =0 ; Destination End Point range 1~3)
Command Class = 0x32	( Command_Class_Meter_V3 = 0x32)

Command =0x01	(Meter_Get = 0x01)
Parameter 1 = 0x10	(Scale = W = 0x02)

PAB01 Instant Power Consumption (W) Report example :

COMMAND_CLASS_MULTI_CHANNEL	
MULTI_CHANNEL_CMD_ENCAP	
Source End Point = 0x03	(Meter report = Endpoint3)
(Bit Address+Destination End Point = 0x05)	(Bit Address =0 ; Destination End Point = command inquirer's Endpoint value)
Command Class = 0x32	(Command_Class_Meter_V3 = 0x32)
Command =0x02	(Meter_Report = 0x02)
Parameter 1 = 0x21	(Scale Bit2 = 0 , Rate Type = 0x01 , Meter Type=0x01)
Parameter 2 = 0x34	(Precision = 1 , Scale Bit1Bit0 = 0x02 , Size = 4)
Parameter 3 = 0x00	Instant Power Consumption =
Parameter 4 = 0x00	0x000003EA
Parameter 5 = 0x03	= 100.2W
Parameter 6 = 0xEA	

**2-3-5-3 Get load voltage V from endpoint**

Meter\_GET example:

COMMAND_CLASS_MULTI_CHANNEL	
MULTI_CHANNEL_CMD_ENCAP	
Source End Point = 0x05	(this is the endpoint of command inquirer, here we assume endpoint is 5·if the inquirer doesn't support multi Channel this value will be 0)
(Bit Address+Destination End Point = 0x03)	(Bit Address =0 ; Destination End Point range1~3)
Command Class = 0x32	( Command_Class_Meter_V3 = 0x32)
Command =0x01	(Meter_Get = 0x01)
Parameter 1 = 0x20	(Scale = V = 0x04)

PAB01 AC input Voltage report example :

COMMAND_CLASS_MULTI_CHANNEL	
MULTI_CHANNEL_CMD_ENCAP	
Source End Point = 0x03	(Meter report = Endpoint3)
(Bit Address+Destination End Point = 0x05)	(Bit Address =0 ; Destination End Point = command inquirer's Endpoint value)
Command Class = 0x32	(Command_Class_Meter_V3 = 0x32)
Command =0x02	(Meter_Report = 0x02)

Parameter 1 = 0xA1	(Scale Bit2 = 1 , Rate Type = 0x01 , Meter Type=0x01)
Parameter 2 = 0x22	(Precision = 1 , Scale Bit1Bit0 = 0x00 , Size = 2)
Parameter 3 = 0x09	Voltage = 0x0910 = 232.0V
Parameter 4 = 0x10	

### 2-3-5-4 Get load current I from endpoint

Meter\_GET example:

COMMAND_CLASS_MULTI_CHANNEL	(this is the endpoint of command inquirer, here we assume endpoint is 5, if the inquirer doesn't support multi Channel this value will be 0)	
MULTI_CHANNEL_CMD_ENCAP		
Source End Point = 0x05		
(Bit Address+Destination End Point = 0x03)		(Bit Address =0 ; Destination End Point range1~3)
Command Class = 0x32		( Command_Class_Meter_V3 = 0x32)
Command =0x01	(Meter_Get = 0x01)	
Parameter 1 = 0x28	(Scale = A = 0x05)	

PAB01 AC input current (I) example :

COMMAND_CLASS_MULTI_CHANNEL	(Meter report = Endpoint3)	
MULTI_CHANNEL_CMD_ENCAP		
Source End Point = 0x03		
(Bit Address+Destination End Point = 0x05)		(Bit Address =0 ; Destination End Point = command inquirer's Endpoint value)
Command Class = 0x32		(Command_Class_Meter_V3 = 0x32)
Command =0x02	(Meter_Report = 0x02)	
Parameter 1 = 0xA1	(Scale Bit2 = 1 , Rate Type = 0x01 , Meter Type=0x01)	
Parameter 2 = 0x4A	(Precision = 2 , Scale Bit1Bit0 = 0x01 , Size = 2)	
Parameter 3 = 0x00	Current = 0x002B = 0.43A	
Parameter 4 = 0x2B		

### 2-3-5-5 Get power factor PF from endpoint

Meter\_GET example:

COMMAND_CLASS_MULTI_CHANNEL	(this is the endpoint of command inquirer, here we assume endpoint is 5 , if the inquirer doesn't support multi Channel this
MULTI_CHANNEL_CMD_ENCAP	
Source End Point = 0x05	



	value will be 0)
(Bit Address+Destination End Point = 0x03)	(Bit Address =0 ; Destination End Point range1~3)
Command Class = 0x32	( Command_Class_Meter_V3 = 0x32)
Command =0x01	(Meter_Get = 0x01)
Parameter 1 = 0x30	(Scale = PF = 0x06)

PAB01 power factor report example :

COMMAND_CLASS_MULTI_CHANNEL	
MULTI_CHANNEL_CMD_ENCAP	
Source End Point = 0x03	(Meter report = Endpoint3)
(Bit Address+Destination End Point = 0x05)	(Bit Address =0 ; Destination End Point = command inquirer's Endpoint value)
Command Class = 0x32	(Command_Class_Meter_V3 = 0x32)
Command =0x02	(Meter_Report = 0x02)
Parameter 1 = 0xA1	(Scale Bit2 = 1 , Rate Type = 0x01 , Meter Type=0x01)
Parameter 2 = 0x51	(Precision = 2 , Scale Bit1Bit0 = 0x10 , Size = 1)

Parameter 3 = 0x63	Power Factor = 0x63 = 0.99
--------------------	----------------------------

Note : If the Destination End Point is 1, it will report the power factor of CT1, but not the sum of PF of CT1 and CT2.

### 3.Multi Channel Association (Only 1 group and 1 node)

The Multi Channel Association Command Class is used to create application bindings to Multi Channel End Point resources as well as to Root Devices. The command class can handle nodes with and without end points.

### 4.Z-Wave's Configuration

Configuration Parameter	Function	Size (Byte)	Value	Unit	Default	Description
1	Watt Meter Report Period	2	0x01-0x7FFF	5s	720	5*720s=3600s=1 hour
2	KWH Meter Report Period	2	0x01-0x7FFF	5s	720	5*720s=3600s=1 hour
3	Slected End Point	1	1-3		3	1 : CT1 2 : CT2 3 : CT1 and CT2
4	Threshold of Current for Load Caution	2	10-6000	0.01A	6000	6000*0.01A=60A
5	Threshold of KWH for Load Caution	2	1-10000	1KWh	10000	
6	Existence of Endpoint3	1	1-2		1	1 : Endpoint3 exist 2 : No Endpoint3

#### 4-1 Watt Meter Report Period:

If the setting is configured for 1hour (set value =720), the PAB01 will report its instant power consumption every 1 hour to the node of correspond Group. The maximum interval to report its instant power consumption is 45 hours ( $5s*32767/3600=45hr$ ).

#### 4-2 KWH Meter Report Period:

If the setting is configured for 1hour (set value =720), the PAB01 will report its Accumulated Power Consumption (KW/h) every 1 hour to the node of correspond Group. The maximum interval to report its Accumulated Power Consumption (KW/h) is 45 hours ( $5s*32767/3600=45hr$ ).

#### 4-3 Selected Endpoint

If Controller can't use Multi\_Channel command class to access the endpoint of PAB01, you may configure the endpoint value to react the Basic Command Class · Binary Switch Command Class or Meter Command Class V3

#### 4-3-1 Selected Endpoint 1 : Default Selected Endpoint is 1

Endpoint 1 is only related to CT1.

#### 4-3-2 Selected Endpoint 2

Endpoint 2 is only related to CT2.

#### 4-3-3 Selected Endpoint 3

Endpoint 3 is related to CT1 and CT2.

Get command	parameter	Report to command sender
Meter_Get	KWh	CT1 KWh1+CT2 KWh2
Meter_Get	Watt	CT1 W1+CT2 W2
Meter_Get	Voltage	CT1 and CT2 are the same voltage
Meter_Get	Current	CT1 I1+CT2 I2
Meter_Get	Power factor PF	Only CT1

#### 4-4 Threshold of Current for Load Caution

This is a warning when the current of load over the preset threshold value, If the setting value is 6000, when the load wattage of CT1 or CT2 over 60A, PAB01 will send current Meter Report command to the node of correspond Group.

#### 4-5 Threshold of KWh for Load Caution

This is a warning when the KWh of load over the preset threshold value, If the setting value is 10000, when the Accumulated Power Consumption of CT1 or CT2 over this value, PAB01 will send KWh Meter Report command to the node of correspond Group, minum value is 1KWh and default value is 10000 kWh

#### 4-6 Existence of Endpoint3 :

Multi-Channel Command is a good way to control relay1 and relay2 of PAB01 individually. The endpoint3 of PAB01 is related to both relay1 and relay2. In some condition it becomes redundant in Multi-Channel Command Class. When the Existence of Endpoint3 is set as 2, the endpoint3 will be disabled. The default value is 1.

Endpoint1 and Endpoint2 are fixed, only Endpoint3 is dynamic.

#### 5.Firmware update over the air (OTA)

PAB01 is based on 500 series SoC and supports Firmware Update Command

Class, it can receives the updated firmware image sent by controller via the Z-wave RF media. It is a helpful and convenient way to improve some function if needed.

#### 6.Command Classes

The Switch supports Command Classes including...

- \* COMMAND\_CLASS\_ZWAVEPLUS\_INFO
- \* COMMAND\_CLASS\_VERSION
- \* COMMAND\_CLASS\_MANUFACTURER\_SPECIFIC\_V2
- \* COMMAND\_CLASS\_DEVICE\_RESET\_LOCALLY
- \* COMMAND\_CLASS\_ASSOCIATION\_V2

- \* COMMAND\_CLASS\_ASSOCIATION\_GRP\_INFO
- \* COMMAND\_CLASS\_POWERLEVEL
- \* COMMAND\_CLASS\_CRC\_16\_ENCAP
- \* COMMAND\_CLASS\_FIRMWARE\_UPDATE\_MD\_V2
- \* COMMAND\_CLASS\_MULTI\_CHANNEL\_V4
- \* COMMAND\_CLASS\_MULTI\_CHANNEL\_ASSOCIATION
- \* COMMAND\_CLASS\_METER\_V3
- \* COMMAND\_CLASS\_CONFIGURATION

## Troubleshooting

Symptom	Cause of Failure	Recommendation
The meter is not working and LED off	1. The meter is not connect to the Main power 2. The meter break down	1. Check power connections 2. Don't open up the meter and send it for repair.
The meter cannot report to the group	1. Not carry out association 2. Same frequency interference	1. Carry out association 2. Wait for a while to re-try

## Specification

Operating Voltage	100~240VAC
Rated Primary Current	0.05A~60A x 2 Channel ; Split Core Transformer
Range	Minimum 40 m in door 100m outdoor line of sight
Operating Temperature	0°C ~ 40°C
Frequency Range	PAB01-1 868.40 & 869.85MHz (EU) / PAB01-2 908.40 & 916.0MHz(USA/Canada) / PAB01-3 922~927MHz (Taiwan/JP)

\*\* Specifications are subject to change and improvement without notice.

**FCC ID : RHHPAB01**



## DANGER

Danger of electrocution!

All works on the device may be performed only by a qualified and licensed electrician.

Observe national regulations.

Any works introducing changes into the configuration must be always performed with disconnected voltage.

Choosing a Suitable Location

1. Do not locate the Module facing direct sunlight, humid or dusty place.
2. The suitable ambient temperature for the Module is 0°C~40°C.
3. Do not locate the Module where exists combustible substances or any source of heat, e.g. fires, radiators, boiler etc.
4. After putting it into use, the body of Module will become a little bit hot of which phenomenon is normal.

## Warning:

1. Plug out to disconnect from power supply; Do not plug in line.
2. Do not exceed the max rating.

## Disposal



This marking indicates that this product should not be disposed with other household wastes throughout the EU. To prevent possible harm to the environment or human health from uncontrolled waste disposal, recycle it responsibly to promote the sustainable reuse of material resources. To return your used device, please use the return and collection systems or contact the retailer where the product was purchased. They can take this product for environmental safe recycling.

Company of License Holder : Philio Technology Corporation

Address of License Holder : 8F.,No.653-2,Zhongzheng Rd., Xinzhuang Dist., New

Taipei City 24257, Taiwan(R.O.C)

### **FCC Interference Statement**

This equipment has been tested and found to comply with the limits for a Class B digital device, pursuant to Part 15 of the FCC Rules.

These limits are designed to provide reasonable protection against harmful interference in a residential installation.

This equipment generates, uses and can radiate radio frequency energy and, if not installed and used in accordance with the instructions, may cause harmful interference to radio communications.

However, there is no guarantee that interference will not occur in a particular installation.

If this equipment does cause harmful interference to radio or television reception, which can be determined by turning the equipment off and on, the user is encouraged to try to correct the interference by one of the following measures:

- Reorient or relocate the receiving antenna.
- Increase the separation between the equipment and receiver.
- Connect the equipment into an outlet on a circuit different from that to which the receiver is connected.
- Consult the dealer or an experienced radio/TV technician for help.

This device complies with Part 15 of the FCC Rules. Operation is subject to the following two conditions:

(1) This device may not cause harmful interference, and

(2) This device must accept any interference received, including interference that may cause undesired operation.

FCC Caution: Any changes or modifications not expressly approved by the party responsible for compliance could void the user's authority to operate this equipment.

This transmitter must not be co-located or operating in conjunction with any other antenna or transmitter.