



Always Connected. Always Covered.

Mouser

DMMZ1



User Manual

Preface

As this is the full User Manual, a working knowledge of Z-Wave automation terminology and concepts will be assumed. If you are a basic user, please visit www.domeha.com for instructions. This manual will provide in-depth technical information about the Mouser, especially in regards to its compliance to the Z-Wave standard (such as compatible Command Classes, Association Group capabilities, special features, and other information) that will help you maximize the utility of this product in your system.

Table of Contents

| | |
|--|----|
| Preface..... | 2 |
| Description & Features..... | 4 |
| Specifications..... | 5 |
| Physical Characteristics | 6 |
| Inclusion & Exclusion..... | 7 |
| Factory Reset & Misc. Functions..... | 8 |
| Physical Installation..... | 9 |
| LED Behavior | 10 |
| Button Behavior..... | 11 |
| Compatible Command Classes..... | 12 |
| “Configuration” Command Class Parameters | 14 |
| Troubleshooting..... | 16 |
| Warranty & Support..... | 17 |

Description & Features

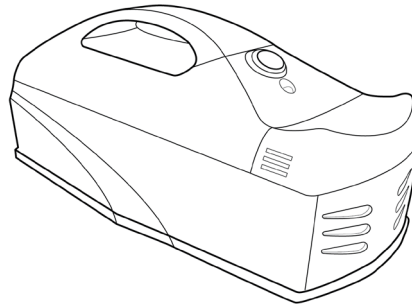

The Dome Mouser is a battery powered Z-Wave Plus enabled mousetrap that works by electrocution and is designed to be humane and painless to the rodent. After a mouse is caught, the Mouser will send a Z-Wave signal to its controller to notify the user, and will not retrigger until the trap is reset.

Key Features:

- » Z-Wave Plus Certified
- » Up to 150' wireless range, depending on environment
- » Quick and painless for both the mouse and the human
- » Mess-free rodent removal
- » Will work with or without Z-Wave connectivity
- » Physical arm/disarm button for added safety
- » Two-Year Battery Life—equivalent to 50+ zaps
- » Low Battery Indication

Specifications

Technical Specifications

| | |
|-------------------------------|-------------------------------------|
| Radio protocol | Z-Wave Plus (500 series) |
| Power supply | 4x 1.5V AA Size |
| Max Current | 100mA |
| Power Consumption | 0.6W |
| Radio frequency | 908.4 MHz US |
| Z-Wave Range | Up to 150' depending on environment |
| Dimensions (L x W x H) | 8.5" x 4.5" x 5" |

Table 1 - Technical Specifications

Package Contents:



User Manual

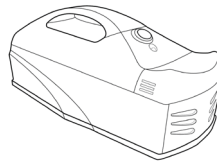

Mouser

Physical Characteristics

The names used in Figures 1 & 2 will be used throughout this manual. Please refer to this page as needed.

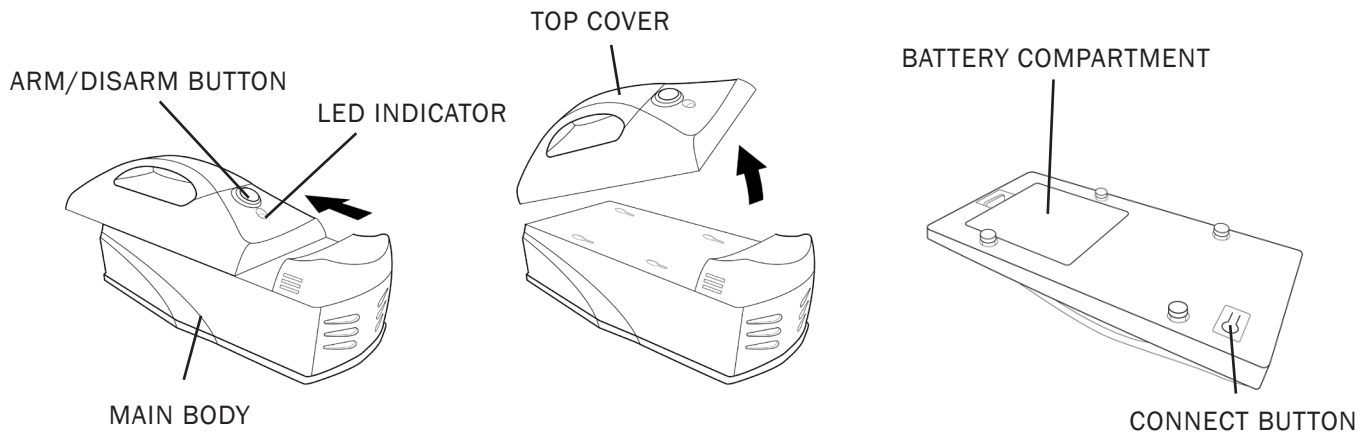

Figure 1 - Parts of the Mouser

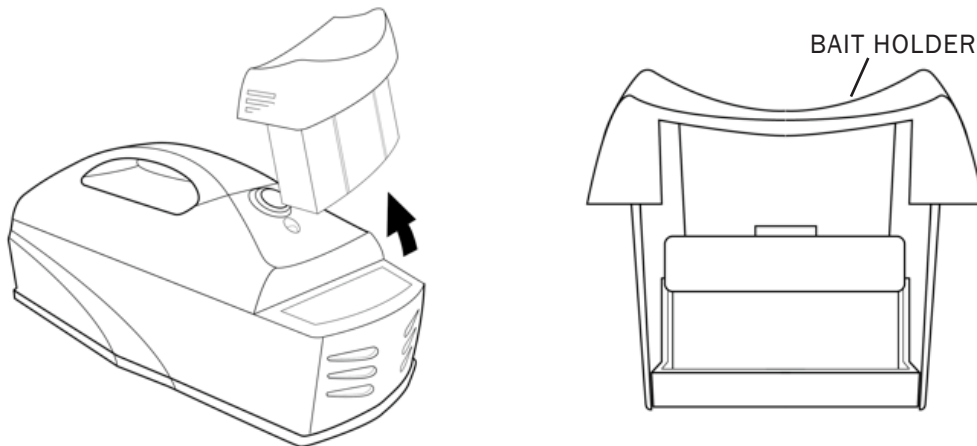

Figure 2 - Removing the BAIT HOLDER

Inclusion & Exclusion

Inclusion

Follow the instructions for your Z-Wave Certified controller to enter inclusion mode. When prompted by the controller:

1. Bring the Mouser to within 10' of your Z-Wave controller for the inclusion process. After successful pairing, the device can be brought to the desired location.
2. Remove top cover by sliding it back and lifting up.
3. Insert batteries.
4. Press the CONNECT BUTTON quickly 3 times in a row.

The LED INDICATOR will flash five times indicating inclusion

Exclusion

Follow the instructions for your Z-Wave Certified controller to enter exclusion mode.

When prompted by the controller:

1. Remove top cover by sliding it back and lifting up.
2. Press the CONNECT BUTTON quickly 3 times in a row.

The LED INDICATOR will flash five times indicating exclusion/disconnection.

Factory Reset & Misc. Functions

Resetting the Mouser

If needed, the Mouser can be reset locally by following these steps. Only do this when your Z-Wave controller is disconnected or otherwise unreachable. Beware that resetting your device will disconnect it from the system:

1. Remove the TOP COVER and confirm that your Mouser is powered up.
2. Press and hold the CONNECT BUTTON for at least 10 seconds then release. A flashing LED INDICATOR indicates a successful factory reset.
3. The Mouser's memory will be erased to factory settings.

Waking Up The Mouser

Because the Mouser is a battery powered device, it wakes up on regular intervals to give battery and other status updates to the controller, as well as to accept configuration settings from the controller. This helps to extend the battery life. The device can be forced to wake up to submit these reports or accept new settings immediately by simply pressing and holding the BUTTON for two seconds. The LED INDICATOR will flash once indicating successful wake up.

Physical Installation

How to Use—Baiting the Trap

1. Lift the BAIT HOLDER from the Mouser.
2. Add bait - dry foods (like peanuts) leave less mess.
3. Replace the BAIT HOLDER.

How to Use—Setting the Trap

1. Bait the Mouser.
2. Place the Mouser in the desired location - rodents usually scurry around walls and other corners.
3. Flip On/Off Button to the On position - the LED will stay lit for two seconds indicating the Mouser is armed. A flashing LED indicates low battery.
4. When the Mouser is tripped. the LED will blink every five seconds, and an alert will be sent to your Z-Wave Controller.
5. Flip the On/Off Button to the Off position to empty the Mouser, and it is ready to use again immediately.

LED Behavior

| Color | Behavior | This happens when... |
|-------|---------------------------------------|---|
| Red | Blink 5 times in 5 seconds (slow) | ...the Mouser was just powered on, but is not yet included in a system. |
| | Blink 5 times in 2.5 seconds (medium) | ...the CONNECT BUTTON is pressed 3 times quickly (regardless of inclusion status.) |
| | Blink 5 times in 1.5 seconds (fast) | ...the Mouser is powered on, and already included in a system. |
| | Stay on for 2+ seconds straight | ...the CONNECT BUTTON is pressed and held for 10+ seconds, resetting Mouser to factory settings OR the CONNECT BUTTON is pushed once. |
| | Blinks once every 3 seconds | ...the trap is tripped and needs to be emptied. |
| | Stays on for 2 seconds | ...Battery is high when the ARM/DISARM BUTTON is pushed to the "Arm" Position |
| | Blinks three times | ...Battery is low when the ARM/DISARM BUTTON is pushed to the "Arm" Position |
| | Stays on constantly | ...Battery is about to die when the ARM/DISARM BUTTON is pushed to the "Arm" Position |

Table 2 - LED Blinking Behavior

Button Behavior

| Action | Condition | Result |
|--|--|--|
| Press and hold CONNECT BUTTON for 2 seconds | Mouser Already Included in System | Device sends a wake up notification to its controller, awaits further instructions, and blinks the LED Indicator once |
| Push CONNECT BUTTON 3 Times | Mouser Already Included in System | Device sends node info to Group 1 |
| | Mouser Already Included, and Controller is in Exclusion Mode | Device is excluded from the system and removes the Home ID from its memory |
| | Mouser Not Yet Included in System, and Controller is in Inclusion Mode | Device enters inclusion mode and includes into whichever network is also in inclusion mode |
| Press and hold CONNECT BUTTON for 10+ seconds | Mouser Already Included in System | Device will be reset to factory settings, and a DEVICE_RESET_LOCALLY command will be sent to Node 1 |
| Press and Hold for 10+ seconds | Any condition (as long as the device has power) | The device's memory will erase to factory default settings and any associations, configuration parameters, and other locally saved data will be lost |

Table 3 - Button Behavior

Compatible Command Classes

| Command Class | Notes |
|---------------------------------------|---|
| Device Reset Locally V1 (5A) | - |
| Powerlevel V1 (73) | - |
| Association Group Information V1 (59) | - |
| Battery V1(80) | - |
| Z-Wave Plus Info V2 (5E) | <p>Returned Value: 01 06 00 0C 07 0C 07</p> <p>Z-Wave Plus Version: 01</p> <p>Role Type: 06 (<i>Slave Sleeping Reporting</i>)</p> <p>Node Type: 00 (<i>Z-Wave Plus Node</i>)</p> <p>Installer Icon Type: 0C 07 (<i>Home Security Alarm</i>)</p> <p>User Icon Type: 0C 07 (<i>Home Security Alarm</i>)</p> |
| Version V2 (86) | <p>Returned Value: 06 04 05 03 10 52 00</p> <p>Z-Wave Library Type: 06 (<i>Enhanced Slave</i>)</p> <p>Protocol Version: 04 05</p> <p>Protocol Sub-Version: 03 10</p> <p>Application Version: 52</p> <p>Application Sub-Version: 00</p> |
| Association V2 (85) | <p>Group 1 Group 1 is the “Lifeline” group, which can hold five members, typically including the main Z-Wave controller. The Door/Window Sensor sends this group a Notification Report and a Binary Sensor Report when it is tripped, reset, armed, and disarmed. It also sends this group a Battery Report in response to Battery Get commands.</p> <p>Group 2 The Mouser sends a Basic Set command to Association Group 2 (or the Control Group) to directly trigger devices (like a light, chime, etc.) when it is tripped. After the trap is reset, a BASIC_SET(00) command is sent to reset the device (e.g. turn off the light.) The value of the Basic Set command (e.g. brightness of the lamp) is configured using configuration parameter 1.</p> <p>Group 3 Group 3 supports up to 5 members and the Mouser sends it a NOTIFICATION_REPORT when tripped, reset, armed, and disarmed.</p> <p>Group 4 Group 4 supports up to 5 members and the Mouser sends it a SENSOR_BINARY_REPORT when tripped, reset, armed, and disarmed.</p> |

Table 4 - Command Classes

| Command Class | Notes |
|-------------------------------|--|
| Notification V4 (71) | <p>The Mouser sends a Notification Report when the trap is triggered, reset, armed, and disarmed. It primarily uses the Pest Control Notification Type, but also sends a Home Security, Motion Detected (Unknown Location) Report when the trap is triggered and a Home Security, Event Inactive when the trap is reset to ensure compatibility with all Z-Wave Controllers.</p> <p style="text-align: center;">Returned Value: 00 00 00 FF 13 XX 00 00</p> <p>V1 Alarm Type: 00 (<i>Unsupported</i>) V1 Alarm Level: 00 (<i>Unsupported</i>) Reserved: 00 (<i>Reserved</i>) Notification Status: FF (<i>Unsolicited Reporting is Enabled</i>) Notification Type: 13 (<i>Pest Control</i>) Event: Pest Exterminated—08 (<i>Pest Exterminated, Unknown Location</i>) Pest Removed—00 (<i>State Cleared</i>) Trap Armed—02 (<i>Trap Armed, Unknown Location</i>) Trap Unarmed—04 (<i>Trap Re-Arm Required, Unknown Location</i>) Sequence/Reserved/Event Parameters Length: 00 Notification Event Parameters: 00 (<i>No Event Parameters</i>)</p> <p style="text-align: center;">Returned Value: 00 00 00 FF 07 XX 00 00</p> <p>V1 Alarm Type: 00 (<i>Unsupported</i>) V1 Alarm Level: 00 (<i>Unsupported</i>) Reserved: 00 (<i>Reserved</i>) Notification Status: FF (<i>Unsolicited Reporting is Enabled</i>) Notification Type: 07 (<i>Home Security</i>) Event: Pest Exterminated—08 (<i>Motion Detected, Unknown Location</i>) Pest Removed—00 (<i>Event Inactive</i>) Sequence/Reserved/Event Parameters Length: 00 Notification Event Parameters: 00 (<i>No Event Parameters</i>)</p> |
| Manufacturer Specific V2 (72) | <p style="text-align: center;">Returned Value: 02 1F 03 01 01</p> <p>Manufacturer ID: 02 1F Product Type: 03 Product ID: 01 04</p> |
| Wake Up V2 (84) | <p>The wake-up interval is set in seconds, and is 43,200 seconds (12 hours) by default. The wake-up interval can be set to any value from 300s (5 minutes) to 16,777,200s (about 190 days) in 60-second increments.</p> |
| Configuration V1 (70) | <p>See ““Configuration” Command Class Parameters” on page 14.</p> |

Table 5 - Command Classes Continued

“Configuration” Command Class Parameters

Configuration parameters are sent using a standard syntax to ensure interoperability between all manufacturers’ products. All values are represented using the hexadecimal number system.

Typical syntax is as shown below. Note that the value sent must be the exact size, in bytes, as accepted by the setting. The “extra” spaces should be filled with zeros (see the “value” column below.)

Example Configuration Parameter: **02 02 00 0A**

| Param # | Size | Value |
|-------------------------|------------------------|----------------------|
| 02 <i>(Param #2)</i> | 02 <i>(2 Bytes)</i> | 00 0A <i>(10)</i> |

| Param # | Size | Name | Available Settings | Default Setting |
|---------|--|----------------------------|--|-----------------------------------|
| 1 | This parameter sets the value sent by the BASIC_SET command to Association Group 2 (for more information, see “Association Groups”). | | | |
| | 01 | BASIC_SET Level | 00 <i>(0/Turn Off Device)</i> 01 ~ 63 <i>(0-99)</i> FF <i>(255/Turn On Device)</i> | FF <i>(255/Turn On Device)</i> |
| 2 | This parameter sets “firing mode” of the Mouser. Two firing modes are available: in the first (Continuous Fire,) electricity is passed continuously for four minutes, and in the second (Burst Fire,) electricity is passed continuously only for the first minute and it is pulsed at approximately 400 beats per minute for the remainder of the time. | | | |
| | 01 | Set Firing Mode | 01 <i>(Continuous Fire)</i> 02 <i>(Burst Fire)</i> | 02 <i>(Burst Fire)</i> |
| 3 | | | | |
| | 02 | High Voltage Duration Time | 00 64~01 68 <i>(100~360 in Seconds)</i> | 64 <i>(100 Seconds)</i> |

Table 6 - Mouser Configuration Parameters

| Param # | Size | Name | Available Settings | Default Setting |
|---------|--|--------------------------|---|----------------------------------|
| 4 | This parameter enables or disables the indicator LED alarm when the trap is tripped. | | | |
| | 01 | Enable/Disable LED Alarm | 00 (LED Alarm Disabled) 01 (LED Alarm Enabled) | 01 (LED Alarm Enabled) |
| 5 | This parameter sets the amount of time the LED Indicator blinks after the trap is tripped. | | | |
| | 01 | LED Alarm Duration | 00 (LED Alarm Blinks Until Trap is Cleared) 01~FF (1~255 in Hours) | 00 (LED Alarm Blinks Cleared) |

Table 7 - Mouser Configuration Parameters

Troubleshooting

Q: Help! My Mouser paired successfully, but my controller can't see it anymore after I installed it!

A: The Z-Wave signal is probably weak in that area of your home. Remember that the 120' - 150' range doesn't take into account walls, furniture, and other obstacles. To boost your Z-Wave network coverage, add a few non-battery powered Z-Wave devices between the controller and the furthest device, like the Dome On/Off Plug or Water Main Shut-Off. You can even purchase dedicated Z-Wave extenders from 3rd party manufacturers.

Q: There's so many words in this manual I don't understand. How can I learn more about Z-Wave?

A: Remember you don't have to understand everything in this manual to start automating your home. Our Quick-Start Guides have all you need to start using any device. For more thorough information about Z-Wave home automation, visit www.domeha.com/support.

Q: I've tried multiple times, but I can't include the Mouser in my system.

A: Make sure your device is getting power. Then, follow the procedure to Factory Reset on Page 8 and try going through the inclusion process again. If you are still having issues, please visit www.domeha.com/support

Q: All of a sudden, my Mouser is offline.

A: Make sure your device is getting power. If powered, make sure you still have Z-Wave network coverage. If you are still having issues, visit www.domeha.com/support.

Q: A red LED is blinking and my device turned off by itself.

A: There was too much current flowing through the Mouser and it was shut off as a precautionary measure. After you make sure the current is back to normal, just push the CONNECT BUTTON once and your device should start working like before.

Warranty & Support

If you have questions, our trained Customer Service Department is happy to assist you 24 hours a day, 7 days a week. Contact Dome Customer Service as follows: • In North America dial: 1-855-249-1754 • Email Dome at support@domeHA.com DO NOT RETURN THIS PRODUCT TO THE STORE OR WEBSITE FROM WHICH IT WAS PURCHASED

If you believe the product is defective, has a missing or broken part or are having difficulty with it please contact Dome as listed above for a quick and efficient solution to the problem.

Legal Notices: This device complies with part 15 of the FCC rules. Operation is subject to the following two conditions (1) This device may not cause harmful interference, and (2) this device must accept any interference received, including interference that may cause undesired operation.

Note: This equipment has been tested and found to comply with the limits for a Class B digital device, pursuant to part 15 of the FCC Rules. These limits are designed to provide reasonable protection against harmful interference in a residential installation. This equipment generates, uses and can radiate radio frequency energy and, if not installed and used in accordance with the instructions, may cause harmful interference to radio communications.

However, there is no guarantee that interference will not occur in a particular installation. If this equipment does cause harmful interference to radio or television reception, which can be determined by turning the equipment off and on, the user is encouraged to try to correct the interference by one or more of the following measures: Reorient or relocate the receiving antenna; increase the separation between the equipment and the receiver; connect the equipment into an outlet on a circuit different from that to which the receiver is connected. Consult the dealer or an experienced radio/TV technician for help.

This device complies with Industry Canada license-exempt RSS standard(s). Operation is subject to the following two conditions: (1) this device may not cause interference, and (2) this device must accept any interference, including interference that may cause undesired operation of the device.

Elexa Consumer Products, Inc. ("ECP") warrants to the original retail purchaser ("Purchaser") that the DOME Window/Door sensor (the "Product") will be free of defects in materials or workmanship under use for one (1) year from the date of purchase (the "Warranty period").

For the Purchaser only, if the Product fails to perform as specified during the Warranty Period due to defective parts or faulty workmanship, ECP will repair or replace the defective or damaged parts of the Product. Normal wear and tear is not covered nor is abnormal use, misuse, mishandling, faulty installation, improper shipping, damage caused by disasters such as fire, flood or earthquake, neglect, accident or tampering. This warranty covers only normal use in the United States or Canada.

To obtain warranty service during the Warranty Period, call Dome Customer Service (1-855-249-1754) or email: support@domeHA.com for instructions on sending damaged parts and documentation for a Return Material Authorization (RMA). Products returned to ECP for repair or replacement without authorization will be returned at the sender's expense. All warranty claims must be accompanied by a legible copy of the original receipt showing date and details of purchase. The RMA number

must be clearly written on the side of the shipping container in which you return the Product or defective parts. Unless otherwise instructed by ECP, the Product must be sent freight prepaid to the following address:

Elexa Consumer Products, c/o Promac,
1153 Timber Dr., Elgin, IL 60123

ECP will repair or replace the defective parts and return them at ECP's cost by a shipping method selected by ECP. When contacting ECP to obtain an RMA, Purchaser may request expedited return shipping at Purchaser's expense.

THIS WARRANTY IS NOT TRANSFERABLE, AND, TO THE MAXIMUM EXTENT PERMITTED BY APPLICABLE LAW IS IN LIEU OF ALL OTHER WARRANTIES, REPRESENTATIONS AND CONDITIONS, EXPRESSED OR IMPLIED, STATUTORY OR OTHERWISE, INCLUDING BUT NOT LIMITED TO THE IMPLIED WARRANTIES OF MERCHANTABILITY AND FITNESS FOR A PARTICULAR PURPOSE. NO OTHER PERSON OR REPRESENTATIVE IS AUTHORIZED TO MAKE ANY OTHER WARRANTY ON BEHALF OF ECP OR ASSUME FOR ECP ANY OTHER LIABILITY IN CONNECTION WITH THE SALE OF THIS PRODUCT. IN NO EVENT WILL ECP BE LIABLE FOR ANY DAMAGES, INCLUDING BUT NOT LIMITED TO INCIDENTAL, SPECIAL OR CONSEQUENTIAL DAMAGES ARISING OUT OF THE USE OR INABILITY TO USE THE PRODUCT, INCLUDING DAMAGES DUE TO ECP'S NEGLIGENCE.

THIS WARRANTY GIVES YOU SPECIFIC LEGAL RIGHTS, AND YOU MAY ALSO HAVE OTHER RIGHTS WHICH VARY FROM STATE TO STATE AND COUNTRY TO COUNTRY.

This marking on the product, accessories or literature indicates that the product and its electronic accessories should not be disposed of with other household waste.

To prevent possible harm to the environment or human health from uncontrolled waste disposal, please separate these items from other types of waste and recycle them responsibly to promote the sustainable reuse of material resources.

Household users should contact either the retailer where they purchased this product, or their government office, for details of where and how they can take these items for environmentally safe recycling.

Business users should contact their supplier and check the terms and conditions of the purchase contract. This product and its electronic accessories should not be mixed with other wastes for disposal.

This marking on the battery, manual or packaging indicates that the batteries in this product should not be disposed of with other household waste. Where marked, the chemical symbols Hg, Cd or Pb indicate that the battery contains mercury, cadmium or lead above the reference levels in EC Directive 2006/66. If batteries are not properly disposed of, these substances can cause harm to human health or the environment.