

0-10 V DIMMER
ZEN54 LR

ZOOZ™
bright ideas
www.getzooz.com
ask@getzooz.com

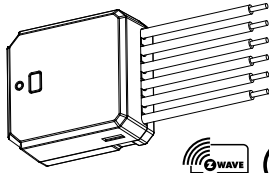

FEATURES

- Z-Wave™ 0-10 V dimming control for LED fixtures
- Great for 0-10 V LED drivers in LED panels
- Smooth dimming with instant status updates
- Installs behind your existing wall switch (on/off or momentary)
- **700 series Z-Wave™** chip for better range and faster control
- **Z-Wave™ Long Range** for ultra reliable no-mesh communication
- Advanced configuration including min and max brightness
- Built-in Z-Wave™ signal repeater for boosted communication
- SmartStart and S2 Security for a safer network

SPECIFICATIONS

- Model Number: ZEN54 LR
- Power Input: 100-240 VAC, 50/60 Hz, max. 4.1 A, 984 W
- Power Output: 100-240 VAC, 50/60 Hz, max. 4 A, 960 W
- **Maximum Load:** 4 A (use with 0-10 V LED drivers only)
- Range: Up to 300 feet line of sight (or up to a mile with LR)
- Operating Temperature: 32-104° F (0-40° C)
- Installation and Use: Indoor only

CAUTION

This is an electrical device - please use caution when installing and operating the 0-10 V Dimmer. Remote control of appliances may result in unintentional or automated activation of power.

Do not use this Z-Wave™ device to control electric heaters or other appliances which produce the risk of fire, burns, or electrical shock when unattended.

To reduce risk of overheating and possible damage to other equipment, do not install this unit to control a receptacle; a motor-operated appliance; a fluorescent lighting fixture; any device over 32 V DC power; or a transformer-supplied fixture. Use with 0-10 V LED drivers only.

BEFORE YOU INSTALL

This device is intended for installation in accordance with the National Electric Code and local regulations. It is recommended that a licensed electrician perform this installation.

WIRING: READ IT!

1. **CHECK THE LOAD:** don't exceed 4 A for your 0-10 V Dimmer, **USE ONLY WITH 0-10 V LED DRIVERS**
2. **POWER OFF:** turn the circuit power off in the breaker panel before you start. If installing in a multi-switch box with multiple circuits, turn power off at all of the circuits.
3. **CHECK THE WIRES:** mark 0-10 V driver connections (GND- and 0-10 V+), power (L and N), load to LED driver (LOAD) and switch connections (SW and GND). **Don't rely exclusively on your multimeter to identify the wires!**

NOT SURE WHAT YOU'RE SEEING? WE'LL HELP! SUPPORT.GETZOOZ.COM
SEND US PICTURES OF YOUR SET-UP, BEFORE YOU DISCONNECT WIRES.

4. **DISCONNECT THE SWITCH:** remove the wires between the switch and the LED driver and label them accordingly.
5. **CONNECT THE 0-10 V DIMMER:** follow all installation steps carefully. Wire the device EXACTLY like in the diagram. Depending on your set-up, you may need to install the device at the LED fixture rather than in the switch box.

ON/OFF OR MOMENTARY SWITCHES ONLY

Do not connect the ZEN54 to a wall dimmer, illuminated switch, or electronic add-on switch. The ZEN54 device can only be wired with on/off or momentary wall switches. Physical dimming available from momentary switches only. With on/off switches, dim via Z-Wave only.



- 1 Connect the driver wires to **GND -** and **0-10V+** on ZEN54.
- 2 Connect the wall switch to the **GND-** bundle and the **SW** pigtail on the ZEN54.
- 3 Connect the **LOAD** on the ZEN54 to the line input on the LED driver.
- 4 Connect neutral from the 120 V power source to **N** on ZEN54 and the neutral input on the LED driver.
- 5 Connect line from the 120 V power source to the **L** pigtail on the ZEN54.

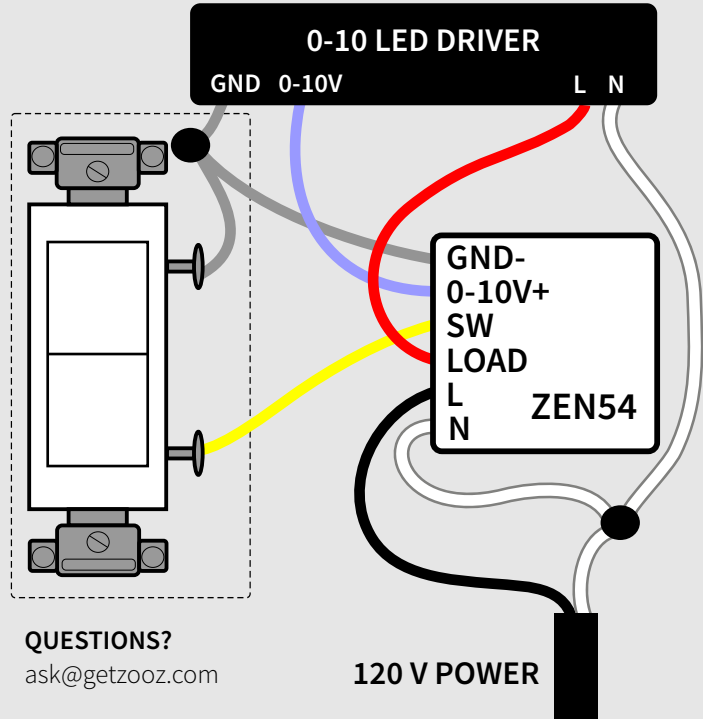

QUESTIONS?

ask@getzooz.com

120 V POWER

COMPLETE INSTALLATION

Secure your Z-Wave™ 0-10 V Dimmer and the wall switch in the box with mounting screws, handling the wires with care. Install the wall plate and restore power to the circuit.

Z-WAVE™ CONTROL



1. **ADD DEVICE** to your hub
Initiate inclusion (pairing) in the app (or web interface). SmartStart enabled products can be added into a Z-Wave™ network by scanning the Z-Wave™ QR Code present on the product with a controller providing SmartStart inclusion.

2. Finalize inclusion at the dimmer.
TAP THE Z-WAVE™ BUTTON 3 TIMES QUICKLY if using traditional Z-Wave™ inclusion.

SCAN THE QR CODE / ENTER THE 5-DIGIT PIN if using the new SmartStart method.

The SmartStart security PIN is located on the back of the relay, next to the Z-Wave Plus™ logo.

The LED indicator will blink green to signal communication and turn green for 2 seconds if inclusion is successful or turn red for 2 seconds if the pairing attempt fails.



NEED SOME HELP? ask@getzooz.com

Choose your hub and scan the QR code with your phone's camera. Then click on the link to access the step-by-step pairing instructions.



Z-Box Hub



Habitat



Home Assistant



SmartThings

Get more tutorials and helpful tips at www.support.getzooz.com

Register your product for extended warranty and direct access to firmware files: getzooz.com/register

The 0-10 V Dimmer adds Z-Wave™ control to your existing 0-10 V LED driver. It cannot be connected to any other type of fixture or appliance.

In most cases, you will have power coming into the wall switch and a load connection between the switch and the LED driver. To accommodate the wiring requirements of the ZEN54 dimmer, you will need to use that connection to bring power to the ZEN54 installed at the fixture. This will not leave enough wires to connect the ZEN54 dimmer to the wall switch directly. In that case, we would recommend installing any Z-Wave™ light switch to control the ZEN54 dimmer remotely via Z-Wave™. The best Zooz models for this application are the ZEN72 Dimmer (for a classic switch look) or the ZEN32 Scene Controller which comes with programmable buttons you can link to your favorite brightness settings on the LED fixture and trigger them with a single tap.

Scan the QR code below to access a page with more wiring scenarios and diagrams.

3-WAY INSTALLATIONS

You can install the 0-10 V dimmer in a 3-way set-up using simple on/off or momentary switches. Scan below to find the right diagram for your scenario.

SCAN FOR MORE WIRING DIAGRAMS



TROUBLESHOOTING

The device won't add to your system? Try this:

1. Initiate **EXCLUSION** and click the Z-Wave™ button 3 times quickly.
2. Click the Z-Wave™ button **4-5 times quickly** to add.
3. Bring the gateway controller (hub) **closer** to the device, it may be out of range.
4. Get troubleshooting tips for your hub at www.support.getzooz.com

EXCLUSION (REMOVING / UNPAIRING DEVICE)

1. Bring your Z-Wave™ hub close to the device if possible
2. Put the Z-Wave™ hub into **exclusion mode** (not sure how to do that? ask@getzooz.com)
3. Click the **Z-Wave™ button** on the device **3 times quickly** (the LED indicator will start blinking green)
4. Your hub will confirm exclusion, the LED indicator on the device will turn green for 2 seconds, and the ZEN54 will disappear from your controller's device list.

FACTORY RESET

If your primary controller is missing or inoperable, you may need to reset the device to factory settings. To reset the ZEN53, **click the Z-Wave™ button once and immediately after, press and hold it down for 15 seconds.** The LED indicator will flash red during the process and turn solid red for 3 seconds to confirm successful reset.

NOTE: All previously recorded activity and custom settings will be erased from the device's memory.

WARNING

- This product should be installed indoors upon completion of any building renovations.
- Prior to installation, the device should be stored in a dry, dust-and-mold-proof place.
- Do not install the device in a place with direct sun exposure, high temperature, or humidity.
- Keep away from chemicals, water, and dust.
- Ensure the device is never close to any heat source or open flame to prevent fire.
- Ensure the device is connected to an electric power source that does not exceed the maximum load power.
- No part of the device may be replaced or repaired by the user.

Here is a selection of settings available to customize your device. **Scan the QR code for a full list of parameters** and look below for how to access them on your hub.

- **Ramp rate** to customize the fad-out and fade-in effect for on/off control
- **Timer** (automatic on/off scheduling)
- **Minimum and maximum** dim levels
- On/off status after **power failure**

SCAN SETTINGS



Choose your hub and scan the QR code with your phone's camera. Then click on the link to learn how to access and change the advanced settings for the device on your hub.



Z-Box Hub



Hubitat



Home Assistant



SmartThings

ASSOCIATION

This 0-10 V Dimmer supports Group 1 with up to 5 devices for Lifeline Group communication and Groups 2-4 with up to 5 devices. This device will send BASIC REPORT and SWITCH MULTILEVEL REPORT to Group 1, BASIC SET command to group 2, SWITCH MULTILEVEL SET to Group 3, and SWITCH MULTILEVEL START LEVEL CHANGE / SWITCH MULTILEVEL STOP LEVEL CHANGE to Group 4 when operated manually from the wall switch. You can set direct association to have the dimmer control another Z-Wave™ device independently of the hub by using Group 2. Not every hub exposes direct association settings in the interface so please go to www.support.getzooz.com to see if your system allows for direct association.



This product can be included and operated in any Z-Wave™ network with other Z-Wave™ certified devices from other manufacturers and/or other applications. All non-battery operated nodes within the network will act as repeaters regardless of vendor to increase reliability of the network.

This product features the latest Security 2 (S2) framework to remove smart home network hacking risks. This device is equipped with a unique authentication code for trusted wireless communication.

This is an ETL certified device. ETL, just like UL, is a Nationally Recognized Testing Laboratory. The ETL mark is proof of product compliance with North American safety standards.

WARRANTY

This product is covered under a 1-year limited warranty and extender 5-year warranty once registered. To read the full warranty policy or file a warranty claim, please go to www.getzooz.com/warranty

IN NO EVENT SHALL ZOOZ OR ITS SUBSIDIARIES AND AFFILIATES BE LIABLE FOR ANY INDIRECT, INCIDENTAL, PUNITIVE, SPECIAL, OR CONSEQUENTIAL DAMAGES, OR DAMAGES FOR LOSS OF PROFITS, REVENUE, OR USE INCURRED BY CUSTOMER OR ANY THIRD PARTY, WHETHER IN AN ACTION IN CONTRACT, OR OTHERWISE EVEN IF ADVISED OF THE POSSIBILITY OF SUCH DAMAGES. ZOOZ'S LIABILITY AND CUSTOMER'S EXCLUSIVE REMEDY FOR ANY CAUSE OF ACTION ARISING IN CONNECTION WITH THIS AGREEMENT OR THE SALE OR USE OF THE PRODUCTS, WHETHER BASED ON NEGLIGENCE, STRICT LIABILITY, BREACH OF WARRANTY, BREACH OF AGREEMENT, OR EQUITABLE PRINCIPLES, IS EXPRESSLY LIMITED TO, AT ZOOZ'S OPTION, REPLACEMENT OF, OR REPAYMENT OF THE PURCHASE PRICE FOR THAT PORTION OF PRODUCTS WITH RESPECT TO WHICH DAMAGES ARE CLAIMED. ALL CLAIMS OF ANY KIND ARISING IN CONNECTION WITH THIS AGREEMENT OR THE SALE OR USE OF PRODUCTS SHALL BE DEEMED WAIVED UNLESS MADE IN WRITING WITHIN THIRTY (30) DAYS FROM ZOOZ'S DELIVERY, OR THE DATE FIXED FOR DELIVERY IN THE EVENT OF NONDELIVERY.

FCC NOTE

THE MANUFACTURER IS NOT RESPONSIBLE FOR ANY RADIO OR TV INTERFERENCE CAUSED BY UNAUTHORIZED MODIFICATIONS TO THIS EQUIPMENT. SUCH MODIFICATIONS COULD VOID THE USER'S AUTHORITY TO OPERATE THE EQUIPMENT. STORE INDOORS WHEN NOT IN USE. SUITABLE FOR DRY LOCATIONS ONLY. DO NOT IMMERSE IN WATER. NOT FOR USE WHERE DIRECTLY EXPOSED TO WATER.

This device complies with Part 15 of the FCC Rules.

Operation is subject to the following conditions:

1. This device may not cause harmful interference,
 2. This device must accept any interference received, including interference that may cause undesired operation.
- This equipment has been tested and found to comply with the limits for a Class B digital device, pursuant to part 15 of the FCC Rules.

These limits are designed to provide reasonable protection against harmful interference in a residential installation.

This equipment generates, uses and can radiate radio frequency energy and, if not installed and used according to instructions, may cause harmful interference to radio communications.

However, there is no guarantee that interference will not occur in any given installation.

If this equipment causes harmful interference to radio or television reception, the user may try to correct the interference by taking one or more of the following measures:

- Reorient or relocate receiving antenna
- Increase the separation between equipment and receiver
- Connect equipment into a separate outlet or circuit from receiver
- Consult the dealer or an experienced radio/TV technician for additional assistance