



Wave 1

Z-Wave® smart switch with potential-free contact

Extended User Guide (EN)

Device: Wave 1

Part number US: QNSW-001X16US

Z-Wave Product type ID: 0x0002

Z-Wave Product ID: 0x0083

Z-Wave Manufacturer: Shelly Europe

Z-Wave Manufacturer ID: 0x0460

Table of contents

1. Terminology	4
2. About Shelly Qubino	4
3. About the Device	4
4. Electrical diagrams (110-240 V AC / 24-48 V DC / 12 V DC)	5
4.1 Installation instruction	6
5. About Z-Wave	8
6. Z-Wave® Adding / Removing / Factory reset	9
6.1 Adding the Device to a Z-Wave® network (inclusion)	9
6.1.1 SmartStart adding (inclusion)	9
6.1.2 Adding (inclusion) with a switch/push-button	9
6.1.3 Adding (inclusion) with the S button	10
6.2 Removing the Device from a Z-Wave® network (exclusion)	10
6.2.1 Removing (exclusion) with a switch/push-button	10
6.2.2 Removing (exclusion) with the S button	11
6.3 Factory reset	11
6.3.1 Factory reset general	11
6.3.2 Factory reset with a switch/push-button	11
6.3.3 Factory reset with the S button	12
6.3.4 Remote factory reset with parameter with the gateway	12
7. Z-Wave® Security 2 and Device Specific Key (DSK).....	13
8. LED Signalisation	15
9. Z-Wave® Parameters	17
Parameter No. 1 - SW (SW1) Switch type.....	17
Parameter No. 17 - Restore state of O (O1) after power failure.....	17
Parameter No. 19 - O (O1) Auto OFF with timer	17
Parameter No. 20 - O (O1) Auto ON with timer	18
Parameter No. 23 - O (O1) contact type - NO/NC	18

Parameter No. 25 - Set timer units to s or ms for O (O1) 19

Parameter No. 91 - Water Alarm 19

Parameter No. 92 - Smoke Alarm 19

Parameter No. 93 - CO Alarm 20

Parameter No. 94 - Heat Alarm 20

Parameter No. 120 - Factory Reset..... 20

Parameter No. 201 - Serial Number 1..... 21

Parameter No. 202 - Serial Number 2..... 21

Parameter No. 203 - Serial Number 3..... 22

10. Z-Wave® Command Class 23

11. Z-Wave® Notifications Command class 25

 11.1 Overheat detected 25

12. Z-Wave® Associations 26

13. Supported load types..... 27

14. Technical Specifications 27

15. Important disclaimer 29

16. Disposal & Recycling 29

 16.1 FCC Notes 29

17. Manufacturer 30

READ BEFORE USE
This document contains important technical and safety information about the Device, its safe use and installation.

 **CAUTION!** Before beginning the installation, please read carefully and entirely this guide and any other documents accompanying the Device. Failure to follow the installation procedures could lead to malfunction, danger to your health and life, violation of law or refusal of legal and/or commercial guarantee (if any). Allterco Robotics EOOD is not responsible for any loss or damage in case of incorrect installation or improper operation of this Device due to failure of following the user and safety instructions in this guide.

1. Terminology

- **Device** - In this document, the term “**Device**” is used to refer to the Shelly Qubino device that is a subject of this guide.
- **Gateway** - A Z-Wave® gateway, also referred to as a Z-Wave® controller, Z-Wave® main controller, Z-Wave® primary controller, or Z-Wave® hub, etc., is a device that serves as a central hub for a Z-Wave® smart home network. The term “**gateway**” is used in this document.
- **S button** - The Z-Wave® Service button, located on Z-Wave® devices and is used for various functions such as adding (inclusion), removing (exclusion), and resetting the device to its factory default settings. The term “**S button**” is used in this document.
- **Adding/Inclusion** - The process of adding Z-Wave device to a Z-Wave network - gateway. The words **included**, **added**, etc. are used in this regard.
- **Removing/Exclusion** - The process of removing Z-Wave device from a Z-Wave network - gateway. The words **excluded**, **removed**, etc. are used in this regard.

2. About Shelly Qubino

Shelly Qubino is a line of innovative microprocessor-managed devices, which allow remote control of electric circuits with a smartphone, tablet, PC, or home automation system. They work on Z-Wave® wireless communication protocol, using a gateway. When the gateway is connected to the internet, you can control Shelly Qubino devices remotely from anywhere. Shelly Qubino devices can be operated in any Z-Wave® network with other Z-Wave® certified devices from other manufacturers. All mains operated nodes within the network will act as repeaters regardless of vendor to increase reliability of the network. Devices are designed to work with older generations of Z-Wave® devices and gateways.

3. About the Device

The Device controls on/off function for one electrical device, e.g., bulb, ceiling fan, IR heater, electrical locks, garage doors, irrigation system, etc. The output contact is potential-free (dry contact), so different power supply loads (up to 15 A) can be connected to the Device. It is compatible with push-buttons and switches (default).

If the SW (SW1) is configured as a switch (default), each toggle of the switch will change the output O (O1) state to the opposite state - on, off, on, etc. If the SW (SW1) is configured as a push-button in the Device settings, each press of the push-button will change the output O (O1) state to the opposite state - on, off, on, etc.

4. Electrical diagrams (110-240 V AC / 24-48 V DC / 12 V DC)

Connecting to the power grid with power supply 110-240 V AC (Fig. 1), or 24-48 V DC (Fig. 2), or 12 V DC (Fig. 3).

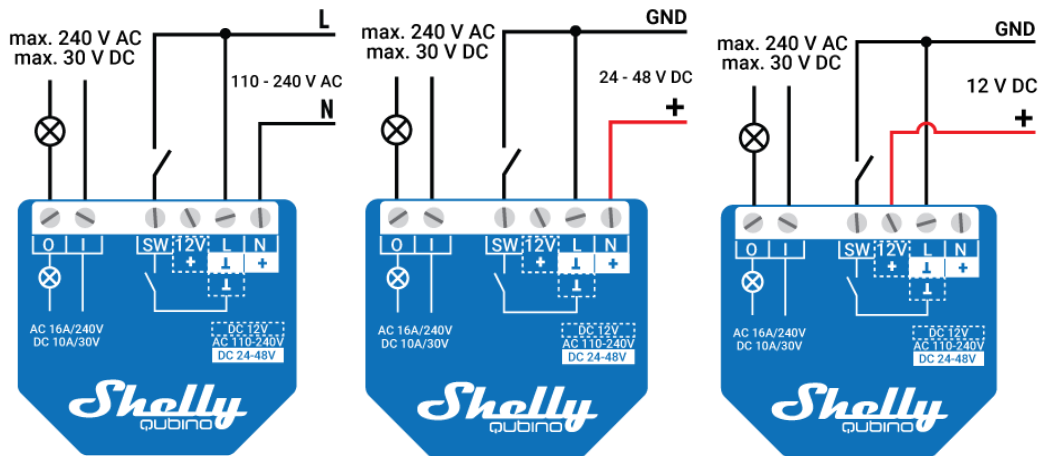

Fig. 1

Fig. 2

Fig. 3

LEGEND

Device terminals:

- **N:** Neutral terminal
- **L:** Live terminal (110-240 V AC)
- **SW (SW1):** Input terminal for switch/push-button controlling O (O1)
- **I:** Load circuit input terminal
- **O (O1):** Output terminal for Load circuit (1)
- **12V+:** 12 V DC positive terminal
- **+:** 24 - 48 V DC positive terminal
- **⚡:** 12 / 24 - 48 V DC ground terminal

Wires:

- **N:** Neutral wire
- **L:** Live wire (110-240 V AC)
- **+:** 24 - 48 V DC positive wire
- **GND:** 12 / 24 - 48 V DC ground wire

Button:

- **S:** S button

4.1 Installation instruction

The Device can control a various type of loads (e.g., bulbs) in one electrical circuit up to 3.5 kW / 240 V AC. It can be retrofitted into standard electrical wall boxes, behind power sockets and light switches or other places with limited space.

⚠CAUTION! Danger of electrocution. Mounting/installation of the Device to the power grid has to be performed with caution, by a qualified electrician.

⚠CAUTION! Danger of electrocution. Every change in the connections has to be done after ensuring there is no voltage present at the Device terminals.

⚠CAUTION! Use the Device only with a power grid and appliances that comply with all applicable regulations. A short circuit in the power grid or any appliance connected to the Device may damage it.

⚠CAUTION! Do not connect the Device to appliances exceeding the given max. load!

⚠CAUTION! Do not shorten the antenna.

⚠CAUTION! Connect the Device only in the way shown in these instructions. Any other method could cause damage and/or injury.

⚠CAUTION! Do not install the Device where it can get wet.

⚠CAUTION! Do not use the Device if it has been damaged!

⚠CAUTION! Do not attempt to service or repair the Device yourself!

⚠CAUTION! Use only one phase AC circuit. Do not use mixed AC and DC circuits.

⚠CAUTION! Before starting the mounting/installation of the Device, check that the breakers are turned off and there is no voltage on their terminals. This can be done with a phase tester or multimeter. When you are sure that there is no voltage, you can proceed to connecting the wires.

⚠CAUTION! Do not allow children to play with the push-buttons/ switches connected to the Device. Keep the devices for remote control of Shelly Qubino (mobile phones, tablets, PCs) away from children.

⚠RECOMMENDATION: Place the antenna as far away as possible from metal elements as they can cause signal interference.

⚠RECOMMENDATION: Connect the Device using solid single-core wires with increased insulation heat resistance not less than PVC T105°C (221°F).

⚠RECOMMENDATION: For inductive appliances that cause voltage spikes during switching on/off, such as electrical motors, fans, vacuum cleaners and similar ones, RC snubber (0.1 μ F / 100 Ω / 1/2 W / 600 VAC) should be connected parallel to the appliance.

Connect the load circuit to the Device **I** and **O** terminals.

If you are using AC power supply for the Device, connect the **Live** wire to the Device **L** terminal, and the **Neutral** wire to the **N** terminal as shown on **Fig. 1**. Connect a switch or a push-button to the Device **SW** terminal and the **Live** wire.

If you are using 24-48 V DC power supply (Fig. 2), connect the + wire to the + and the **GND** wire to the **⊥** terminals of the Device.

If you are using stabilized 12 V DC power supply (Fig. 3), connect the + wire to the **12V+** terminal, instead to the + terminal. Connect the switch/push-button to the “**SW**” terminal and the **GND** wire.

5. About Z-Wave®



The Z-Wave® protocol is an interoperable, wireless, RF-based communications technology designed specifically for control, monitoring, and status reading applications in residential and light commercial environments. Mature, proven, and broadly deployed, Z-Wave® is by far the world market leader in wireless control, bringing affordable, reliable, and easy-to-use 'smart' products to millions of people in every aspect of daily life.

Interoperability has always been at the core of the Z-Wave® protocol, alongside the features like backward compatibility, security, and reliability. All Z-Wave® devices can be operated in any Z-Wave® network with other Z-Wave® certified devices, regardless of brand or manufacturer. All mains operated nodes within the network will act as repeaters regardless of vendor to increase the reliability of the network. There are 4000+ Z-Wave certified products that are backwards- and forwards-compatible in the Z-Wave® ecosystem and well over 100 million devices currently in the market.

With over 20 years in the marketplace, Z-Wave® technology has best-in-class security measures to keep your home network smarter and safer.

Source: www.z-wavealliance.org, <http://www.z-wave.com>

6. Z-Wave® Adding / Removing / Factory reset

6.1 Adding the Device to a Z-Wave® network (inclusion)

Note! All Device outputs (O, O1, O2, etc. - depending on the Device type) will turn the load 1s on/1s off /1s on/1s off if the Device is successfully added to/removed from a Z-Wave® network.

Note! In case of Security 2 (S2) adding (inclusion), a dialog will appear asking you to enter the corresponding PIN Code (5 underlined digits) that are written on the Z-Wave® DSK label on the side of the Device and on the Z-Wave® DSK label inserted in the packaging.

IMPORTANT: The PIN Code must not be lost.

6.1.1 SmartStart adding (inclusion)

SmartStart enabled products can be added into a Z-Wave® network by scanning the Z-Wave® QR Code present on the Device with a gateway providing SmartStart inclusion. No further action is required, and the SmartStart device will be added automatically within 10 minutes of being switched on in the network vicinity.

1. With the gateway application scan the QR code on the Device label and add the Security 2 (S2) Device Specific Key (DSK) to the provisioning list in the gateway.
2. Connect the Device to a power supply.
3. Check if the blue LED is blinking in Mode 1. If so, the Device is not added to a Z-Wave® network.
4. Adding will be initiated automatically within a few seconds after connecting the Device to a power supply, and the Device will be added to a Z-Wave® network automatically.
5. The blue LED will be blinking in Mode 2 during the adding process.
6. The green LED will be blinking in Mode 1 if the Device is successfully added to a Z-Wave® network.

6.1.2 Adding (inclusion) with a switch/push-button

1. Connect the Device to a power supply.
2. Check if the blue LED is blinking in Mode 1. If so, the Device is not added to a Z-Wave® network.
3. Enable add/remove mode on the gateway.
4. Toggle the switch/push-button connected to any of the SW terminals (SW, SW1, SW2, etc.) 3 times within 3 seconds (this procedure puts the Device in Learn mode*). The Device must receive on/off signal 3 times, which means pressing the momentary switch 3 times, or toggling the switch on and off 3 times.
5. The blue LED will be blinking in Mode 2 during the adding process.

6. The green LED will be blinking in Mode 1 if the Device is successfully added to a Z-Wave® network.

***Learn mode** - a state that allows the Device to receive network information from the gateway.

6.1.3 Adding (inclusion) with the S button

1. Connect the Device to a power supply.
2. Check if the blue LED is blinking in Mode 1. If so, the Device is not added to a Z-Wave® network.
3. Enable add/remove mode on the gateway.
4. To enter the Setting mode, quickly press and hold the S button on the Device until the LED turns solid blue.
5. Quickly release and then press and hold (> 2s) the S button on the Device until the blue LED starts blinking in Mode 3. Releasing the S button will start the Learn mode.
6. The blue LED will be blinking in Mode 2 during the adding process.
7. The green LED will be blinking in Mode 1 if the Device is successfully added to a Z-Wave® network.

Note! *In Setting mode, the Device has a timeout of 10s before entering again into Normal mode.*

6.2 Removing the Device from a Z-Wave® network (exclusion)

Note! *The Device will be removed from your Z-Wave® network, but any custom configuration parameters will not be erased.*

Note! *All Device outputs (O, O1, O2, etc. - depending on the Device type) will turn the load 1s on/1s off /1s on/1s off if the Device is successfully added to/removed from a Z-Wave® network.*

6.2.1 Removing (exclusion) with a switch/push-button

1. Connect the Device to a power supply.
2. Check if the green LED is blinking in Mode 1. If so, the Device is added to a Z-Wave® network.
3. Enable add/remove mode on the gateway.
4. Toggle the switch/push-button connected to any of the SW terminals (SW, SW1, SW2,...) 3 times within 3 seconds (this procedure puts the Device in Learn mode). The Device must receive on/off signal 3 times, which means pressing the momentary switch 3 times, or toggling the switch on and off 3 times.
5. The blue LED will be blinking in Mode 2 during the removing process.

6. The blue LED will be blinking in Mode 1 if the Device is successfully removed from a Z-Wave® network.

6.2.2 Removing (exclusion) with the S button

1. Connect the Device to a power supply.
2. Check if the green LED is blinking in Mode 1. If so, the Device is added to a Z-Wave® network.
3. Enable add/remove mode on the gateway.
4. To enter the Setting mode, quickly press and hold the S button on the Device until the LED turns solid blue.
5. Quickly release and then press and hold (> 2s) the S button on the Device until the blue LED starts blinking in Mode 3. Releasing the S button will start the Learn mode.
6. The blue LED will be blinking in Mode 2 during the removing process.
7. The blue LED will be blinking in Mode 1 if the Device is successfully removed from a Z-Wave® network.

Note! *In Setting mode, the Device has a timeout of 10s before entering again into Normal mode.*

6.3 Factory reset

6.3.1 Factory reset general

After Factory reset, all custom parameters and stored values (kWh, associations, routings, etc.) will return to their default state. HOME ID and NODE ID assigned to the Device will be deleted. Use this reset procedure only when the gateway is missing or otherwise inoperable.

6.3.2 Factory reset with a switch/push-button

Note! *Factory reset with a switch/push-button is only possible within the first minute after the Device is connected to a power supply.*

1. Connect the Device to a power supply.
2. Toggle the switch/push-button connected to any of the SW terminals (SW, SW1, SW2,...) 5 times within 3 seconds. The Device must receive on/off signal 5 times, which means pressing the push-button 5 times, or toggling the switch on and off 5 times.
3. During factory reset, the LED will turn solid green for about 1s, then the blue and red LED will start blinking in Mode 3 for approx. 2s.
4. The blue LED will be blinking in Mode 1 if the Factory reset is successful.

6.3.3 Factory reset with the S button

Note! *Factory reset with the S button is possible anytime.*

1. To enter the Setting mode, quickly press and hold the S button on the Device until the LED turns solid blue.
2. Press the S button multiple times until the LED turns solid red.
3. Press and hold (> 2s) S button on the Device until the red LED starts blinking in Mode 3. Releasing the S button will start the factory reset.
4. During factory reset, the LED will turn solid green for about 1s, then the blue and red LED will start blinking in Mode 3 for approx. 2s.
5. The blue LED will be blinking in Mode 1 if the Factory reset is successful.

6.3.4 Remote factory reset with parameter with the gateway

Factory reset can be done remotely with the settings in Parameter No. 120.

7. Z-Wave® Security 2 and Device Specific Key (DSK)

The Device supports the latest Security 2 (S2) feature. S2 is handled by the strong AES 128 Encryption protocol, which means that the S2 makes Z-Wave® the most secure IoT (Internet of Things) security platform out there. To fully utilize the product and its Security 2 feature, a Security 2-enabled Z-Wave® gateway must be used.

Authenticated Control

- Out-Of-Band DSK for adding (inclusion)
- May be used by most implementations

The Device also supports Security 2 Authenticated, Unauthenticated, and Unsecure adding (inclusion).

Note! When adding the Device to a Z-Wave network with a gateway supporting Security 2 (S2), the PIN Code of the Z-Wave Device Specific Key (DSK) is required. You can find it on the label on the side of the Device and a copy is inserted in the packaging, which must not be lost. Do not remove the Z-Wave DSK label from the Device. As a backup measure, use the label in the packaging.



The first five digits of the key are highlighted or underlined to help the user identify the PIN Code part of the DSK text. The DSK is additionally represented with a QR Code as shown on the image.

DSK label and QR code (example)

A joining node requesting to join the S2 Access Control Class or the S2 Authenticated Class will obfuscate its Public Key by setting the bytes 1..2 to zeros (0x00) before transferring its key via RF.

The DSK may be used for out-of-band (OOB) authentication.

The including gateway may use a QR code scanning device to read the entire DSK of the joining device and match it with the obfuscated public key received via RF from the joining device.

① NOTE: This Device must be used in conjunction with a Security Enabled Z-Wave gateway to fully utilize all implemented functions.

① NOTE: This Device is a security enabled Z-Wave Plus® product that can use encrypted Z-Wave Plus® messages to communicate to other security enabled Z-Wave Plus® products.

① NOTE: DSK access via UI gateways, which implement the S2 and SmartStart security feature, display an input dialog box, with a full or partial DSK key. Most of them display a partial DSK (they do not show the PIN code) when the Device is added (included) with the S2-Authenticated security scheme. When added (included) with the S2-Unauthenticated, some gateways show the complete DSK while others perform the complete adding (inclusion) process without prompting the user with the dialogue.

8. LED Signalisation



General rules

- Switching between Normal and Settings mode is done by pressing the S button once.
- **Solid LED** means that you are in **Setting mode** (this does not apply to plugs). Once you are in Setting mode, it automatically switches to Normal mode after 10s.
- If the LED is not in Alarm mode, it will turn off after a timeout of 30 min (this does not apply to plugs). Press on the S button or Device power cycle wakes the LED up for 30 min.

Normal mode LED status: Normal mode is defined by a stable device function that can last infinitely long.

Normal mode	Colour ↓	LED status	LED blinking mode	Blinking frequency	LED duration
Removed/Excluded	Blue	Blinking 	Mode 1	0,5s On / 2s Off	30 min after every power cycle and 30 min after the S button was pressed, regardless of when the power cycle was finished.
Added/Included	Green	Blinking 	Mode 1	0,5s On / 2s Off	10s after every power cycle.
Settings in progress mode	Colour	LED status	LED blinking mode	Blinking frequency	LED duration
Factory reset and reboot	Green / Blue / Red	During factory reset, the LED will turn solid green for about 1s (undefined in SW), then the blue and red LED will start blinking 0,1s On, 0,1s Off for about 2s.			During the process, regardless of when the power cycle was finished.
Adding / Removing (Inclusion / Exclusion)	Blue	Blinking 	Mode 2	0,5s On / 0,5s Off	During the process, regardless of when the power cycle was finished.
OTA firmware updating	Blue / Red	Blinking 	Mode 2	0,5s On / 0,5s Off	During the process, regardless of when the power cycle was finished.

Setting mode (with S button)	Colour	LED status	LED blinking mode	Blinking frequency	LED duration
------------------------------	--------	------------	-------------------	--------------------	--------------

Adding / Removing (Inclusion / Exclusion) menu selected	Blue	On	Solid	On	During the process, regardless of when the power cycle was finished (it lasts max. 10s).
Adding / Removing (Inclusion / Exclusion) menu - while pressing S button - Adding / Removing (Inclusion / Exclusion) process selected	Blue	Blinking 	Mode 3	0,1s On / 0,1s Off	During the process, regardless of when the power cycle was finished.
Factory reset menu selected	Red	On	Solid	On	During the process, regardless of when the power cycle was finished (it lasts max. 10s).
Factory reset - while pressing S button - Factory reset process selected	Red	Blinking 	Mode 3	0,1s On / 0,1s Off	During the process, regardless of when the power cycle was finished.

Alarm mode	Colour	LED status	LED blinking mode	Blinking frequency	LED duration
------------	--------	------------	-------------------	--------------------	--------------

Overheat detected	Red	Blinking 	Mode 4 (2x)	0,2s On 0,2s Off 0,2s On 0,2s Off 2s Off and repeating this sequence	During an active alarm, regardless of when the power cycle was finished.
-------------------	-----	---	-------------	--	--

9. Z-Wave® Parameters

Parameter No. 1 - SW (SW1) Switch type

This parameter defines how the Device should treat the switch (which type) connected to the SW (SW1) terminal.

Value size: 1 Byte

Default value: 2

Values & descriptions:

- 0 - momentary switch,
- 1 - toggle switch (contact closed - ON / contact opened - OFF),
- 2 - toggle switch (Device changes status when switch changes status)

Parameter No. 17 - Restore state of O (O1) after power failure

This parameter determines if the on/off status is saved and restored for the load connected to O (O1) after a power failure.

Values size: 1 Byte

Default value: 0

Values & descriptions:

- 0 - Device saves last on/off status and restores it after a power failure
- 1 - Device does not save on/off status and does not restore it after a power failure, it remains off

Parameter No. 19 - O (O1) Auto OFF with timer

If the load O (O1) is ON, you can schedule it to turn OFF automatically after the period of time defined in this parameter. The timer resets to zero each time the Device receives an ON command, either remotely (from the gateway or associated device) or locally from the switch.

Values size: 2 Byte

Default value: 0

Values & their descriptions:

- 0 - Auto OFF Disabled

- 1 - 32535 = 1 - 32535 seconds (or milliseconds – see Parameter no. 25. Auto OFF timer enabled for a given amount of seconds (or milliseconds) resolution 100ms

Parameter No. 20 - O (O1) Auto ON with timer

If the load O (O1) is OFF, you can schedule it to turn ON automatically after the period of time defined in this parameter. The timer resets to zero each time the Device receives an OFF command, either remotely (from the gateway or associated device) or locally from the switch.

Values size: 2 Byte

Default value: 0

Values & their descriptions:

- 0 - Auto ON Disabled
- 1 - 32535 = 1 - 32535 seconds (or milliseconds – see Parameter No. 25. Auto ON timer enabled for a given amount of seconds (or milliseconds) resolution 100ms

Parameter No. 23 - O (O1) contact type - NO/NC

The set value determines the relay contact type for output O (O1) . The relay contact type can be normally open (NO) or normally closed (NC).

Values size: 1 Byte

Default value: 0

Values & descriptions:

- 0 - NO
- 1 - NC

Relay logic:

Par-NO/NC	Command (switch, Z-Wave,..)	Device output state
NO (0)	OFF	OFF (0 V)
NO (0)	ON	ON (230 V)
NC (1)	OFF	ON (230 V)
NC (1)	ON	OFF (0 V)

Parameter No. 25 - Set timer units to s or ms for O (O1)

Set the timer units to seconds or milliseconds. Choose if you want to set the timer in seconds or milliseconds in Parameters No. 19, 20.

Values size: 1 Byte

Default value: 0

Values & descriptions:

- 0 – timer set in seconds
- 1 – timer set in milliseconds

Parameter No. 91 - Water Alarm

This parameter determines which alarm frames the Device should respond to and how. The parameters consist of 4 bytes, the three most significant bytes are set according to the official Z-Wave protocol specification.

Values size: 4 Byte

Default value: 0

Values & descriptions:

- 0 no action
- 1 open relay
- 2 close relay

Parameter No. 92 - Smoke Alarm

This parameter determines which alarm frames the Device should respond to and how. The parameters consist of 4 bytes, the three most significant bytes are set according to the official Z-Wave protocol specification.

Values size: 4 Byte

Default value: 0

Values & descriptions:

- 0 no action
- 1 open relay
- 2 close relay

Parameter No. 93 - CO Alarm

This parameter determines which alarm frames the Device should respond to and how. The parameters consist of 4 bytes, the three most significant bytes are set according to the official Z-Wave protocol specification.

Values size: 4 Byte

Default value: 0

Values & descriptions:

- 0 no action
- 1 open relay
- 2 close relay

Parameter No. 94 - Heat Alarm

This parameter determines which alarm frames the Device should respond to and how. The parameters consist of 4 bytes, the three most significant bytes are set according to the official Z-Wave protocol specification.

Values size: 4 Byte

Default value: 0

Values & descriptions:

- 0 no action
- 1 open relay
- 2 close relay

Parameter No. 120 - Factory Reset

Reset to factory default settings and removed from the Z-Wave network.

The parameter is Advanced and may be hidden under the Advanced tag.

Values size: 1 Byte

Default value: 0

Values & descriptions:

- 0 - Don't do Factory reset
- 1 - Do the Factory reset

Parameter No. 201 - Serial Number 1

This parameter contains a part of device's serial number.

The parameter is Read-Only and cannot be changed.

The parameter is Advanced and may be hidden under the Advanced tag.

Values size: 4 Byte

Default value: Device specific

Values & descriptions:

- 0x00000000 - 0x7FFFFFFF

Parameter No. 202 - Serial Number 2

This parameter contains a part of device's serial number.

The parameter is Read-Only and cannot be changed.

The parameter is Advanced and may be hidden under the Advanced tag.

Values size: 4 Byte

Default value: Device specific

Values & descriptions:

- 0x00000000 - 0x7FFFFFFF

Parameter No. 203 - Serial Number 3

This parameter contains a part of device's serial number.

The parameter is Read-Only and cannot be changed.

The parameter is Advanced and may be hidden under the Advanced tag.

Values size: 4 Byte

Default value: Device specific

Values & descriptions:

- 0x00000000 - 0x7FFFFFFF

10. Z-Wave® Command Class

1. ASSOCIATION_V2 [S0, S2]*
2. ASSOCIATION_GRP_INFO_V3 [S0, S2]*
3. BASIC_V2 [S0, S2]*
4. SWITCH_BINARY_V2 [S0, S2]*
5. CONFIGURATION_V4 [S0, S2]*
6. DEVICE_RESET_LOCALLY_V1 [S0, S2]*
7. FIRMWARE_UPDATE_MD_V5 [S0, S2]*
8. INDICATOR_V3 [S0, S2]*
9. MANUFACTURER_SPECIFIC_V2 [S0, S2]*
10. MULTI_CHANNEL_ASSOCIATION_V3 [S0, S2]*
11. NOTIFICATION_V8 [S0, S2]*
12. POWERLEVEL_V1 [S0, S2]*
13. SECURITY_V1
14. SECURITY_2_V1
15. SUPERVISION_V1
16. TRANSPORT_SERVICE_V2
17. VERSION_V3 [S0, S2]*
18. ZWAVEPLUS_INFO_V2

*[S2] Security S2 Command Class

① NOTE: MAPPING OF COMMAND_CLASS_BASIC

Supporting Command Class Basic

COMMAND_CLASS_BASIC is mapped into COMMAND_CLASS_SWITCH_BINARY, for enabling Switch (O) control:

Switch (O) will be turned ON or OFF, after receiving the BASIC_SET command:

Basic Command received	Mapped Command (binary Switch)
Basic Set (0xFF)	Switch binary Switch (0xFF)
Basic Set (0x00)	Switch binary Switch (0x00)
Basic GET	Basic Report (Current Value, Target Value)

Supporting Command Class Indicator

The Device supports the Command Class Indicator V3 (ID 0x50). When the Device receives an indicator set, the LED blinks according to the received indicator set.

Refer to the LED Signalization chapter.

11. Z-Wave® Notifications Command class

11.1 Overheat detected

Z-Wave Notification Type Name	Z-Wave Notification Name	LED colour status	Device reaction	Action to restore	Device specific	Z-Wave definition
Heat Alarm	Overheat detected	Check the RGB LED signalization table	Switch OFF all outputs and send a notification	Any of the following activities reset this alarm: power cycle, , short press on the S button, press on any switch/push-button connected to any SW (SW, SW1, SW2, ...) terminal.	YES	notification type=heat alarm Value=0x04, event=State Notificatio name=Overheat detected Value=0x02, Version=V2

12. Z-Wave® Associations

Associations are used for direct communication between the Device and other devices within your Z-Wave network without the need of the Z-Wave gateway.

Max. number of associated devices per group is 9. This value is fixed and can not be configured. Each association group supports the association of up to 9 devices (nodes). To avoid network delays, we recommend limiting the amount of associated devices to no more than 5 per group. “Lifeline Group” is reserved solely for a gateway and hence only 1 node can be assigned.

Device	Endpoint	Group	triggered by	reporting to	Command classes
Wave 1	Root device	Group 1 (Lifeline)	Device	GW	<ul style="list-style-type: none"> INDICATOR_REPORT : LED status DEVICE_RESET_LOCALLY_NOTIFICATION : triggered upon request SWITCH_BINARY_REPORT : status change report for output O (O1) NOTIFICATION_REPORT : triggered on Overheat detected
Wave 1	Root device	Group 2 (On/Off)	SW	Associated device	<ul style="list-style-type: none"> BASIC_SET : set On / Off state at the associated device
Wave 1	Root device	Group 3 (Start/Stop set level)	SW	Associated device	<ul style="list-style-type: none"> SWITCH_MULTILEVEL_START_LEVEL_CHANGE : initiate a transition to a new level SWITCH_MULTILEVEL_STOP_LEVEL_CHANGE : stop an ongoing transition

13. Supported load types

- Resistive (incandescent bulbs, heating devices)
- Inductive with RC Snubber (LED light drivers, transformers, fans, refrigerators, air-conditioners)
- Capacitive (capacitor banks, electronic equipment, motor start capacitors)

14. Technical Specifications

Power supply	110-240 V AC / 24-48 V DC / 12 V DC \pm 10%
Power consumption	< 0.3 W
Max. switching voltage AC	240 V
Max. switching current AC	15 A
Max. switching voltage DC	30 V
Max. switching current DC	10 A
Overheating protection	Yes
Distance	Up to 40 m indoors (131 ft.) (depends on local condition)
Z-Wave® repeater:	Yes
CPU	Z-Wave® S800
Z-Wave® frequency bands:	908,4MHz
Maximum radio frequency power transmitted in frequency band(s)	< 25 mW
Size (H x W x D)	37x42x16 \pm 0.5 mm / 1.46x1.65x0.63 \pm 0.02 in
Weight	26 g / 0.92 oz.
Mounting	Wall console
Screw terminals max. torque	0.4 Nm / 3.5 lbin
Conductor cross section	0.5 to 1.5 mm ² / 20 to 16 AWG

Conductor stripped length	5 to 6 mm / 0.20 to 0.24 in
Shell material	Plastic
Color	Blue
Ambient temperature	-20°C to 40°C / -5°F to 105°F
Humidity	30% to 70% RH
Max. altitude	2000m / 6562 ft.

15. Important disclaimer

Z-Wave® wireless communication may not always be 100% reliable. This Device should not be used in situations in which life and/or valuables are solely dependent on its functioning. If the Device is not recognized by your gateway or appears incorrectly, you may need to change the Device type manually and ensure that your gateway supports Z-Wave Plus® multi-level devices.

16. Disposal & Recycling

This refers to the waste of electrical and electronic equipment. It is applicable in the US and other countries to collect waste separately.



This symbol on the product or in the accompanying literature indicates that the product should not be disposed of in the daily waste. Wave 1 must be recycled to avoid possible damage to the environment or human health from uncontrolled waste disposal and to promote the reuse of materials and resources. It is your responsibility to dispose of the device separately from general household waste when it is already unusable.

16.1 FCC Notes

- This device complies with Part 15 of the FCC Rules.
- Operation is subject to the following two conditions:
 - (1) this device may not cause harmful interference
 - (2) this device must accept any interference received, including interference that may cause undesired operation.
- The manufacturer is not responsible for any radio or TV interference caused by unauthorized modification or change to this equipment. Such modifications or change could void the user's authority to operate the equipment.
- This equipment has been tested and found to comply with the limits for a Class B digital device, pursuant to part 15 of the FCC Rules. These limits are designed to provide reasonable protection against harmful interference in a residential installation. This equipment generates, uses, and can radiate radio frequency energy and, if not installed and used in accordance with the instructions, may cause harmful interference to radio

communications. However, there is no guarantee that interference will not occur in a particular installation. If this equipment does cause harmful interference to radio or television reception, which can be determined by turning the equipment off and on, the user is encouraged to try to correct the interference by one or more of the following measures:

- Reorient or relocate the receiving antenna.
- Increase the separation between the equipment and receiver.
- Connect the equipment into an outlet on a circuit different from that to which the receiver is connected.
- Consult the dealer or an experienced radio/TV technician for help.
- RF exposure statement:
 - This equipment complies with FCC radiation exposure limits set forth for an uncontrolled environment. The device has been evaluated to meet general RF exposure requirement. The device can be used in portable exposure condition without restriction

17. Manufacturer

Shelly Europe Ltd. (former Allterco Robotics EOOD)
Address: 103 Cherni vrah Blvd., 1407 Sofia, Bulgaria
Tel.: +359 2 988 7435
E-mail: zwave-shelly@shelly.cloud

Support: <https://support.shelly.cloud/>

Web: <https://www.shelly.cloud>

Changes in the contact data are published by the Manufacturer at the official website:
<https://www.shelly.cloud>



v2.6