



# Wave PM Mini

## Z-Wave® smart power meter

### Extended User Guide (en)

**Device: Wave PM Mini**

EU Part number/Ordering Code: QMEM-0A1PC16EU

Z-Wave Product type ID: 0x0007

Z-Wave Product ID: 0x0081

Z-Wave Manufacturer: Shelly Europe

Z-Wave Manufacturer ID: 0x0460

# Table of contents

1. Terminology .....	4
2. About Shelly Qubino .....	4
3. About the Device .....	5
4. Electrical diagrams 110-240 V AC .....	5
5. Installation instruction.....	6
6. About Z-Wave® .....	7
7. Z-Wave® Adding / Removing / Factory reset .....	7
7.1 Adding the Device to a Z-Wave® network (inclusion) .....	7
7.1.1. SmartStart adding (inclusion) .....	8
7.1.2. Adding (inclusion) with the S button .....	8
7.2 Removing the Device from a Z-Wave® network (exclusion) .....	8
7.2.1. Removing (exclusion) with the S button.....	9
7.3 Factory reset .....	9
7.3.1. Factory reset general .....	9
7.3.2. Factory reset with the S button .....	9
7.3.3. Remote factory reset with parameter with a gateway .....	9
8. Z-Wave® Security 2 and Device Specific Key (DSK).....	10
9. LED Signalization .....	11
General rules.....	11
Removed/Excluded .....	11
Added/Included .....	12
Factory reset and reboot .....	12
Adding / Removing.....	12
OTA firmware updating .....	12
Checking power supply 230 V AC frequency or 24 V DC voltage .....	12
Settings mode with S button .....	12
Adding / Removing menu selected.....	12
Adding / Removing menu - while pressing S- button - Add/Remove process selected .....	13

Factory reset menu selected .....	13
Factory reset - while pressing S - button - Factory reset process selected .....	13
Alarm Mode .....	13
10. Z-Wave® Parameters .....	13
Parameter No. 36 - O (O1) Power report on change - percentage .....	13
Parameter No. 39 - Minimum time between reports (O) O1 .....	14
Parameter No. 120 - Factory Reset.....	14
Parameter No. 201 - Serial Number 1.....	14
Parameter No. 202 - Serial Number 2.....	15
Parameter No. 203 - Serial Number 3.....	15
11. Z-Wave Command Class .....	16
12. Z-Wave Notifications Command class .....	17
Overheat detected .....	17
13. Z-Wave Associations .....	17
13.1. Root device .....	19
Root device - Association Group 1 - Lifeline .....	19
14. Supported load types.....	19
15. Technical Specifications .....	20
16. Important disclaimer .....	21
17. Declaration of Conformity .....	21
18. Manufacturer.....	22

## READ BEFORE USE

**This document contains important technical and safety information about the Device, its safe use and installation.**

**⚠CAUTION!** Before beginning the installation, please read carefully and entirely this guide and any other documents accompanying the Device. Failure to follow the installation procedures could lead to malfunction, danger to your health and life, violation of law or refusal of legal and/or commercial guarantee (if any). Shelly Europe Ltd. is not responsible for any loss or damage in case of incorrect installation or improper operation of this Device due to failure of following the user and safety instructions in this guide.

# 1. Terminology

- **Device** - In this document, the term “**Device**” is used to refer to the Shelly Qubino device that is a subject of this guide.
- **Gateway (GW)** - A Z-Wave® gateway, also referred to as a Z-Wave® controller, Z-Wave® main controller, Z-Wave® primary controller, or Z-Wave® hub, etc., is a device that serves as a central hub for a Z-Wave® smart home network. The term “**gateway**” is used in this document.
- **S button** - The Z-Wave® Service button, located on Z-Wave® devices and is used for various functions such as adding (inclusion), removing (exclusion), and resetting the device to its factory default settings. The term “**S button**” is used in this document.
- **Adding/Inclusion** - The process of adding Z-Wave device to a Z-Wave network - gateway. The words **included, added**, etc. are used in this regard.
- **Removing/Exclusion** - The process of removing Z-Wave device from a Z-Wave network - gateway. The words **excluded, removed**, etc. are used in this regard.
- **Learn mode** - a state that allows the Device to receive network information from the gateway.

# 2. About Shelly Qubino

Shelly Qubino is a line of innovative microprocessor-managed devices, which allow remote control of electric circuits with a smartphone, tablet, PC, or home automation system. They work on Z-Wave® wireless communication protocol, using a gateway, which is required for a configuration of devices. When the gateway is connected to the internet, you can control Shelly Qubino devices remotely from anywhere. Shelly Qubino devices can be operated in any Z-Wave® network with other Z-Wave® certified devices from other manufacturers. All mains operated nodes within the network will act as repeaters regardless of vendor to increase reliability of the network. Devices are designed to work with older generations of Z-Wave® devices and gateways.

### 3. About the Device

The Device is a small form factor smart power meter, which allows remote monitoring of electric appliances power consumption with a load of up to 16 A.

### 4. Electrical diagrams 110-240 V AC

Connecting to the power grid with power supply 110-240 V AC (Fig. 1).

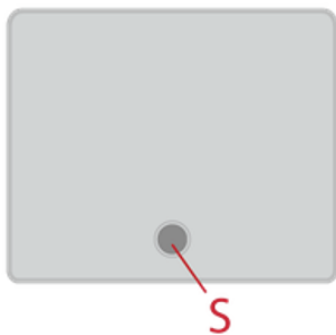
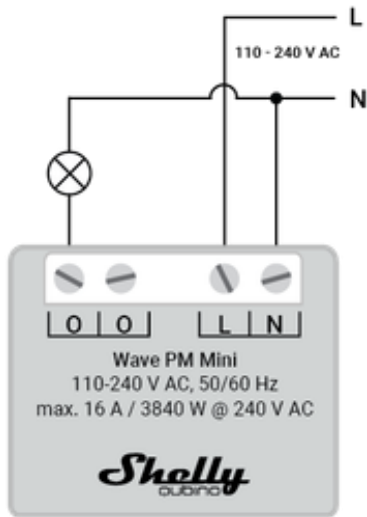

#### Device terminals:

- **N:** Neutral terminal
- **L:** Live terminal (110-240 V AC)

- **O:** Load circuit output terminals (bridged internally)  
**Wires:**
- **N:** Neutral wire
- **L:** Live wire (110-240 V AC)  
**Button:**
- **S:** S button

## 5. Installation instruction

The Device can be retrofitted into standard electrical wall boxes, behind power sockets, or in other places with limited space.

For the installation instructions, refer to the wiring schemas (Fig.1) in this user guide.

**⚠CAUTION!** Danger of electrocution. Mounting/installation of the Device to the power grid must be performed with caution, by a qualified electrician.

**⚠CAUTION!** Danger of electrocution. Every change in the connections must be done after ensuring there is no voltage present at the Device terminals.

**⚠CAUTION!** Use the Device only with a power grid and appliances that comply with all applicable regulations. A short circuit in the power grid or any appliance connected to the Device may damage it.

**⚠CAUTION!** Do not open the Device. It does not contain any parts that can be maintained by the user. For safety and licensing reasons, unauthorized change and/or modification of the Device is not permitted.

**⚠CAUTION!** The load current circuit must be secured by a cable protection switch in accordance with EN60898-1 (tripping characteristic B or C, max. 16 A rated current, min. 6 kA interrupting rating, energy limiting class 3).

**⚠CAUTION!** No SELV/PELV circuits may be connected to the terminals of the inputs and outputs, including the extension inputs.

**⚠CAUTION!** Do not connect the Device to appliances exceeding the given max. load!

**⚠CAUTION!** Do not shorten the antenna.

**⚠CAUTION!** Connect the Device only in the way shown in these instructions. Any other method could cause damage and/or injury.

**⚠CAUTION!** Do not install the Device where it can get wet.

**⚠CAUTION!** Do not use the Device if it has been damaged!

**⚠CAUTION!** Do not attempt to service or repair the Device yourself!

**⚠CAUTION!** Before starting the mounting/installation of the Device, check that the breakers are turned off and there is no voltage on their terminals. This can be done with a mains voltage tester or multimeter. When you are sure that there is no voltage, you can proceed to connecting the wires.

⚠CAUTION! Do not allow children to play with the push-buttons/ switches connected to the Device. Keep the devices for remote control of Shelly Qubino (mobile phones, tablets, PCs) away from children.

△RECOMMENDATION: Place the antenna as far away as possible from metal elements as they can cause signal interference.

△RECOMMENDATION: Connect the Device using solid single-core cables or stranded cables with ferrules. The cables should have insulation with increased heat resistance, not less than PVC T105°C (221°F).

Connect the load-s to the **O** terminals of the Device and the **Neutral** wire, as shown on **Fig. 1**.

Connect the **Live** wire to an **L** terminal of the Device.

Connect the **Neutral** wire to a **N** terminal of the Device.

## 6. About Z-Wave®

The Z-Wave® protocol is an interoperable, wireless, RF-based communications technology designed specifically for control, monitoring, and status reading applications in residential and light commercial environments. Mature, proven, and broadly deployed, Z-Wave® is by far the world market leader in wireless control, bringing affordable, reliable, and easy-to-use 'smart' products to millions of people in every aspect of daily life.

Interoperability has always been at the core of the Z-Wave® protocol, alongside the features like backward compatibility, security, and reliability. All Z-Wave® devices can be operated in any Z-Wave® network with other Z-Wave® certified devices, regardless of brand or manufacturer. All mains operated nodes within the network will act as repeaters regardless of vendor to increase the reliability of the network. There are 4000+ Z-Wave certified products that are backwards- and forwards-compatible in the Z-Wave® ecosystem and well over 100 million devices currently in the market.

With over 20 years in the marketplace, Z-Wave® technology has best-in-class security measures to keep your home network smarter and safer.

Source: [www.Z-Wavealliance.org](http://www.Z-Wavealliance.org), <http://www.Z-Wave.com>

## 7. Z-Wave® Adding / Removing / Factory reset

### 7.1 Adding the Device to a Z-Wave® network (inclusion)

**Note!** In case of Security 2 (S2) adding (inclusion), a dialog will appear asking you to enter the corresponding PIN Code (5 underlined digits) that are written on the Z-Wave® DSK label on the side of the Device and on the Z-Wave® DSK label inserted in the packaging.

IMPORTANT: The PIN Code must not be lost.

### **7.1.1. SmartStart adding (inclusion)**

SmartStart enabled products can be added into a Z-Wave® network by scanning the Z-Wave® QR Code present on the Device with a gateway providing SmartStart inclusion. No further action is required, and the SmartStart device will be added automatically within 10 minutes of being switched on in the network vicinity.

1. With the gateway application scan the QR code on the Device label and add the Security 2 (S2) Device Specific Key (DSK) to the provisioning list in the gateway.
2. Connect the Device to a power supply.
3. Check if the blue LED is blinking in Mode 1. If so, the Device is not added to a Z-Wave® network.
4. Adding will be initiated automatically within a few seconds after connecting the Device to a power supply, and the Device will be added to a Z-Wave® network automatically.
5. The blue LED will be blinking in Mode 2 during the adding process.
6. The green LED will be blinking in Mode 1 if the Device is successfully added to a Z-Wave® network.

### **7.1.2. Adding (inclusion) with the S button**

1. Connect the Device to a power supply.
2. Check if the blue LED is blinking in Mode 1. If so, the Device is not added to a Z-Wave® network.
3. Enable add/remove mode on the gateway.
4. To enter the Setting mode, quickly press and hold the S button on the Device until the LED turns solid blue.
5. Quickly release and then press and hold (> 2s) the S button on the Device until the blue LED starts blinking in Mode 3. Releasing the S button will start the Learn mode.
6. The blue LED will be blinking in Mode 2 during the adding process.
7. The green LED will be blinking in Mode 1 if the Device is successfully added to a Z-Wave® network.

**Note!** In Setting mode, the Device has a timeout of 10s before entering again into Normal mode.

## **7.2 Removing the Device from a Z-Wave® network (exclusion)**

**Note!** The Device will be removed from your Z-Wave® network, but any custom configuration parameters will not be erased.



### **7.2.1. Removing (exclusion) with the S button**

1. Connect the Device to a power supply.
2. Check if the green LED is blinking in Mode 1. If so, the Device is added to a Z-Wave® network.
3. Enable add/remove mode on the gateway.
4. To enter the Setting mode, quickly press and hold the S button on the Device until the LED turns solid blue.
5. Quickly release and then press and hold (> 2s) the S button on the Device until the blue LED starts blinking in Mode 3. Releasing the S button will start the Learn mode.
6. The blue LED will be blinking in Mode 2 during the removing process.
7. The blue LED will be blinking in Mode 1 if the Device is successfully removed from a Z-Wave® network.

**Note!** *In Setting mode, the Device has a timeout of 10s before entering again into Normal mode.*

## **7.3 Factory reset**

### **7.3.1. Factory reset general**

After Factory reset, all custom parameters and stored values (kWh, associations, routings, etc.) will return to their default state. HOME ID and NODE ID assigned to the Device will be deleted. Use this reset procedure only when the gateway is missing or otherwise inoperable.

### **7.3.2. Factory reset with the S button**

**Note!** *Factory reset with the S button is possible anytime.*

1. To enter the Setting mode, quickly press and hold the S button on the Device until the LED turns solid blue.
2. Press the S button multiple times until the LED turns solid red.
3. Press and hold (> 2s) S button on the Device until the red LED starts blinking in Mode 3. Releasing the S button will start the factory reset.
4. During factory reset, the LED will turn solid green for about 1s, then the blue and red LED will start blinking in Mode 3 for approx. 2s.
5. The blue LED will be blinking in Mode 1 if the Factory reset is successful.

### **7.3.3. Remote factory reset with parameter with a gateway**

Factory reset can be done remotely with the settings in Parameter No. 120.

## 8. Z-Wave® Security 2 and Device Specific Key (DSK)

The Device supports the latest Security 2 (S2) feature. S2 is handled by the strong AES 128 Encryption protocol, which means that the S2 makes Z-Wave® the most secure IoT (Internet of Things) security platform out there. To fully utilize the product and its Security 2 feature, a Security 2-enabled Z-Wave® gateway must be used.

Authenticated Control

- Out-Of-Band DSK for adding (inclusion)
- May be used by most implementations

**The Device also supports Security 2 Authenticated, Unauthenticated, and Unsecure adding (inclusion).**

**Note!** When adding the Device to a Z-Wave network with a gateway supporting Security 2 (S2), the PIN Code of the Z-Wave Device Specific Key (DSK) is required. You can find it on the label on the side of the Device and a copy is inserted in the packaging, which must not be lost. Do not remove the Z-Wave DSK label from the Device. As a backup measure, use the label in the packaging.



The first five digits of the key are highlighted or underlined to help the user identify the PIN Code part of the DSK text. The DSK is additionally represented with a QR Code as shown on the image.

**Z-Wave DSK label and QR code (example)**

A joining node requesting to join the S2 Access Control Class or the S2 Authenticated Class will obfuscate its Public Key by setting the bytes 1...2 to zeros (0x00) before transferring its key via RF.

The DSK may be used for out-of-band (OOB) authentication.

The including gateway may use a QR code scanning device to read the entire DSK of the joining device and match it with the obfuscated public key received via RF from the joining device.

① NOTE: This Device must be used in conjunction with a Security Enabled Z-Wave gateway to fully utilize all implemented functions.

① NOTE: This Device is a security enabled Z-Wave Plus® product that can use encrypted Z-Wave Plus messages to communicate to other security enabled Z-Wave Plus products.

① NOTE: DSK access via UI gateways, which implement the S2 and SmartStart security feature, display an input dialog box, with a full or partial DSK key. Most of them display a partial DSK (they do not show the PIN code) when the Device is added with the S2-Authenticated security scheme. When added with the S2-Unauthenticated, some gateways show the complete DSK while others perform the complete adding (inclusion) process without prompting the user with the dialogue.

## 9. LED Signalization

**LED type: RGB dimmable**

### General rules

- Switching between Normal and Settings mode is done by Single press on the S button
- **Solid LED** means that you are in the **Settings mode** (this is not valid for Plugs). Once in settings mode, switch to normal mode goes automatically after 10s
- If the LED is not in Alarm mode, it will turn off after a timeout of 30 min. Pressing the S button or power cycling the Device will wake the LED for 30 min.

Normal mode LED status: Normal mode is defined by stable device function that can remain for an infinite time.

### Normal mode

### Removed/Excluded

The LED will be blinking **blue** in Mode 1 for 30 min after every power cycle and 10 min after S button pressed.

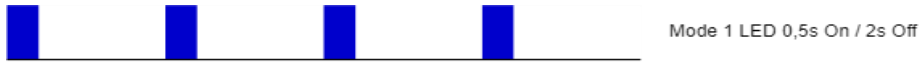

### Added/Included

The LED will be blinking **green** in Mode 1 for 30 min after every power cycle and 10 min after S button pressed.

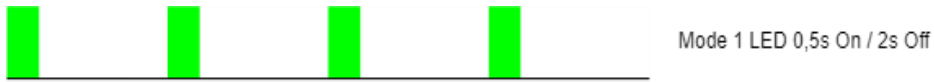

Settings in progress

### Factory reset and reboot

During factory reset, the LED will turn solid **green** for approx. 1sec, then the **blue** and **red** LED will be blinking 0,1s On / 0,1s Off for about 2sec.

### Adding / Removing

During adding or removing, the LED will be blinking **blue** in Mode 2.

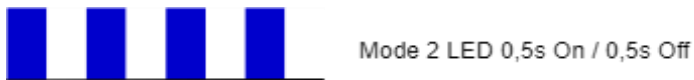

### OTA firmware updating

During the OTA update, the LED will be blinking **blue** and **red** in Mode 2.



### Checking power supply 230 V AC frequency or 24 V DC voltage

During checking the power supply, the LED will be blinking **blue** and **red** in Mode 5.



### Settings mode with S button

### Adding / Removing menu selected

When the menu is selected the LED will be on **blue**, for maximum of 10 seconds.

## **Adding / Removing menu - while pressing S- button - Add/Remove process selected**

When the menu is executing the LED will be blinking **blue** in Mode 3.



## **Factory reset menu selected**

When the menu is selected the LED will be on **red**, for maximum of 10 seconds.

## **Factory reset - while pressing S - button - Factory reset process selected**

When the menu is executing the LED will be blinking **red** in Mode 3.



## **Alarm Mode**

### **Overheat detected**

The LED will be blinking **red** in Mode 4



# **10. Z-Wave® Parameters**

## **Parameter No. 36 - O (O1) Power report on change - percentage**

This parameter determines the minimum change in consumed power that will result in sending a new report to the gateway.

Values size: 1 Byte

Default value: 50

Values & descriptions:

- 0 - reports are disabled
- 1-100 (1-100%) - change in power

*NOTE: When the Device reports the power consumption (W), it will also automatically report the voltage (V) and current (A).*

*NOTE: Regardless of the power consumption change in percentage, the report will not be sent more frequently than defined by Parameter No. 39.*

### **Parameter No. 39 - Minimum time between reports (O) O1**

This parameter determines the minimum time that must elapse before a new power report on O (O1) is sent to the gateway.

Values size: 1 Byte

Default value: 30

Values & descriptions:

- 0 - reports are disabled
- 1-120 (1-120s) - report interval

*NOTE: This Parameter is in relation to Parameter No. 36.*

*NOTE: Setting the value to less than 30s can cause the Z-Wave network congestion state (slow Device response and decreased network stability).*

### **Parameter No. 120 - Factory Reset**

Reset to factory default settings and removed from the Z-Wave network.

The parameter is Advanced and may be hidden under the Advanced tag.

Values size: 1 Byte

Default value: 0

Values & descriptions:

- 0 - No action
- 1 - Factory reset

*After reset is performed, the parameter value is automatically set to 0.*

### **Parameter No. 201 - Serial Number 1**

This parameter contains a part of device's serial number.

The parameter is Read-Only and cannot be changed.

The parameter is Advanced and may be hidden under the Advanced tag.

Values size: 4 Byte

Default value: Device specific

Values & descriptions:

0x00000000 - 0x7FFFFFFF

### **Parameter No. 202 - Serial Number 2**

This parameter contains a part of device's serial number.

The parameter is Read-Only and cannot be changed.

The parameter is Advanced and may be hidden under the Advanced tag.

Values size: 4 Byte

Default value: Device specific

Values & descriptions:

0x00000000 - 0x7FFFFFFF

### **Parameter No. 203 - Serial Number 3**

This parameter contains a part of device's serial number.

The parameter is Read-Only and cannot be changed.

The parameter is Advanced and may be hidden under the Advanced tag.

Values size: 4 Byte

Default value: Device specific

Values & descriptions:

0x00000000 - 0x7FFFFFFF

# 11. Z-Wave Command Class

1. ASSOCIATION\_V2 [S0, S2]\*
2. ASSOCIATION\_GRP\_INFO\_V3 [S0, S2]\*
3. CONFIGURATION\_V4 [S0, S2]\*
4. DEVICE\_RESET\_LOCALLY\_V1 [S0, S2]\*
5. FIRMWARE\_UPDATE\_MD\_V5 [S0, S2]\*
6. INDICATOR\_V3 [S0, S2]\*
7. MANUFACTURER\_SPECIFIC\_V2 [S0, S2]\*
8. METER\_V6 [S0, S2]\*
9. MULTI\_CHANNEL\_ASSOCIATION\_V3 [S0, S2]\*
10. NOTIFICATION\_V8 [S0, S2]\*
11. POWERLEVEL\_V1 [S0, S2]\*
12. SECURITY\_V1
13. SECURITY\_2\_V1
14. SUPERVISION\_V1
15. TRANSPORT\_SERVICE\_V2
16. VERSION\_V3 [S0, S2]\*
17. ZWAVEPLUS\_INFO\_V2

[S2]\* Security S2 Command Class

## **Supporting Command Class Indicator**

The Device supports the Command Class Indicator V3 (ID 0x50). When the Device receives an indicator set, the LED blinks according to the received indicator set.

Refer to LED Signalization chapter.

## **Supporting Meter Command Class**

The product supports the meter command class and KWh is the default scale report send when the scale type is not present in the received Get.

Supported Scale Name	Scale Value
Watt	2
KWh	0



## 12. Z-Wave Notifications Command class

### Overheat detected

Comment	Overheat detected
Z-Wave Notification Type Name	Heat Alarm
Z-Wave Notification type - Value	0x04
Z-Wave Notification type - Event	State
Z-Wave Notification Name	Overheat detected
Z-Wave Notification Name - Value	0x02
Z-Wave Notification Name - Version	V2
LED signalisation	Check LED signalisation table
Device reaction - Switch OFF all outputs and send notification	Yes
Action to restore - power cycle	Yes
Action to restore - short press on S button	Yes

### Over-current detected O

#### Comment

Z-Wave Notification Type Name  
 Z-Wave Notification type - Value  
 Z-Wave Notification type - Event  
 Z-Wave Notification Name  
 Z-Wave Notification Name - Value  
 Z-Wave Notification Name - Version  
 LED signalisation  
 Device reaction - Switch OFF the output O (O1) and send a notification  
 Action to restore - power cycle  
 Action to restore - short press on S button

#### Over-current detected O (O1)

Power management  
 0x08  
 State  
 Over-current detected  
 0x06  
 V3  
 Check LED signalisation table  
 Yes  
 Yes  
 Yes

## AC mains disconnected

### Comment

Z-Wave Notification Type Name  
Z-Wave Notification type - Value  
Z-Wave Notification type - Event  
Z-Wave Notification Name  
Z-Wave Notification Name - Value  
Z-Wave Notification Name - Version  
LED signalisation  
Device reaction - Switch OFF all outputs and send notification  
Action to restore - power cycle  
Action to restore - short press on S button

### AC mains disconnected (valid for AC and DC power supply)

Power management  
0x08  
State  
AC mains disconnected  
0x02  
V2  
Check LED signalisation table  
Yes  
Yes  
Yes

## Over-voltage detected

### Comment

Z-Wave Notification Type Name  
Z-Wave Notification type - Value  
Z-Wave Notification type - Event  
Z-Wave Notification Name  
Z-Wave Notification Name - Value  
Z-Wave Notification Name - Version  
LED signalisation  
Device reaction - Switch OFF all outputs and send notification  
Action to restore - power cycle  
Action to restore - short press on S button

### Over-voltage detected

Power management  
0x08  
State  
Over-voltage detected  
0x07  
V3  
Check LED signalisation table  
Yes  
Yes  
Yes

## 13. Z-Wave Associations

Associations are used for direct communication between the Device and other devices within your Z-Wave network without the need of the Z-Wave gateway.

Max. number of associated devices per group is 9. This value is fixed and cannot be configured. Each association group supports the association of up to 9 devices (nodes). To avoid network delays, we recommend limiting the number of associated devices to no more than 5 per group. "Lifeline Group" is reserved for controlling devices, such as Gateways and remote controllers, or devices who can interpret the reports sent.

**Association group 1** – "Lifeline Group" sends to the controlling device it's command class notifications and or command class reports when said command classes are triggered. Max. 9 nodes are allowed:

### 13.1. Root device

#### Root device - Association Group 1 - Lifeline

1. INDICATOR\_REPORT : LED status
2. DEVICE\_RESET\_LOCALLY\_NOTIFICATION : triggered upon request
3. NOTIFICATION\_REPORT : triggered on Overheat
4. NOTIFICATION\_REPORT : triggered on Overcurrent detected O (O1)
5. NOTIFICATION\_REPORT : triggered on Overvoltage detected
6. NOTIFICATION\_REPORT : triggered on AC mains disconnected
7. METER\_REPORT : triggered by load power consumption connected to output O(O1)  
(according to the settings of Parameters No. 36 and 39)

## 14. Supported load types

- Resistive (incandescent bulbs, heating devices)
- Inductive with RC Snubber (LED light drivers, transformers, fans, refrigerators, air-conditioners)
- Capacitive (capacitor banks, electronic equipment, motor start capacitors)

## 15. Technical Specifications

Power supply	110 - 240 V AC, 50/60 Hz
Power consumption	< 0,3 W
Power measurement (W)	Yes
External protection	16 A, tripping characteristic B or C 6 kA interrupting rating Energy limiting class 3
Max. measurement power	3840 W
Max measurement current	16 A
Overheating protection	Yes
Distance	Up to 40 m indoors (131 ft.) (depends on local condition)
Z-Wave® repeater	Yes
CPU	Z-Wave® S800
Z-Wave® frequency bands	868,4 MHz
Maximum radio frequency power transmitted in frequency band(s)	< 25 mW
Size (H x W x D)	29x35x16 ±0.5 mm / 1.11x1.35x0.63 ±0.02 in
Weight	13 ±1 g / 0.46 ±0.04 oz
Mounting	Wall box
Screw terminals max. torque	0.4 Nm / 3.54 lbin
Conductor cross section	0.5 to 1.5 mm <sup>2</sup> / 20 to 16 AWG
Conductor stripped length	5 to 6 mm / 0.20 to 0.24 in
Shell material	Plastic
Color	Light grey
Ambient temperature	-20°C to 40°C / -5°F to 105°F

Humidity	30% to 70% RH
Max. altitude	2000 m / 6562 ft.

## 16. Important disclaimer

Z-Wave® wireless communication may not always be 100% reliable. This Device should not be used in situations in which life and/or valuables are solely dependent on its functioning. If the Device is not recognized by your gateway or appears incorrectly, you may need to change the Device type manually and ensure that your gateway supports Z-Wave Plus® multi-channel devices.

## 17. Declaration of Conformity

Hereby, Shelly Europe Ltd. (former Allterco Robotics EOOD) declares that the radio equipment type Wave PM Mini is in compliance with Directive 2014/53/ EU, 2014/35/EU, 2014/30/EU, 2011/65/EU. The full text of the EU declaration of conformity is available at the following internet address: <https://shelly.link/WavePMMini-DoC>

# 18. Manufacturer

Shelly Europe Ltd. (former Allterco Robotics EOOD)

Address: 103 Cherni vrah Blvd., 1407 Sofia, Bulgaria

Tel.: +359 2 988 7435

E-mail: [zwave-shelly@shelly.cloud](mailto:zwave-shelly@shelly.cloud)

Support: <https://support.shelly.cloud/>

Web: <https://www.shelly.com>

Changes in the contact data are published by the Manufacturer at the official website:

<https://www.shelly.com>

