

Yale Locks

Z-Wave Plus™ System Integrators Guide **Yale Assure Electronic Connected Deadbolts**

Document Revision: 1.0

July 2023

Contents

Revision History.....	3
Yale Z-Wave Plus™ Product Info	4
Network Operations	4
Enroll/Add device to network (Classic Inclusion Mode) for Assure 2 Lock	4
Un-enroll/Remove device from network (Exclusion Mode).....	4
Factory Reset	5
Supported Command Classes	5
Command Class Z-Wave Plus™ Info, Version 2	5
Command Class Manufacturer Specific, Version 2	6
Command Class Security, Version 1.....	7
Command Class Device Reset Locally, Version 1	7
Command Class Power Level, Version 1	7
Command Class Version, Version 2.....	8
Command Class Battery, Version 1*	9
Command Class Door Lock, Version 2*	9
Command Class Door Lock Logging, Version 1*	9
Command Class Schedule Entry Lock, Version 3*	9
Command Class User Code, Version 1*	10
Command Class Time Parameters, Version 1*	12
Command Class Time, Version 2*	12
Command Class Firmware Update Meta Data, Version 3*	13
Command Class Association, Version 2*.....	13
Command Class Association Group Info, Version 1*	14
Command Class Notification, Version 4*	16
Command Class Configuration, Version 1*	20
Yale Locks in Z-Wave 500 Series System Best Practices	23
Communication Signal Format	23
Commands Communication Timing.....	24

* This command class requires security.

Revision History

Rev.	Details
1.0	Initial Release

Yale Z-Wave Plus™ Product Info

Manufacturer ID: ASSA ABLOY (0x0129)

Z-Wave™ Device Type: Door Lock Keypad





Z-Wave™ Role Type: Listening Sleeping Slave (LSS)

Network Operations

Enroll/Add device to network (Classic Inclusion Mode) for Assure 2 Lock



Un-enroll/Remove device from network (Exclusion Mode)

- Enter the 4–8-digit Master PIN code followed by the  key.
- Press the  key followed by the  key.
- Press the  key followed by the  key.

When the Yale lock is unenrolled/excluded from the network through the device menu mode, any changes previously made to the user code database and configuration settings will be retained, as opposed to set back to defaults.

Factory Reset

- Factory resetting the lock with the Z-Wave™ module installed will clear the Z-Wave™ network settings, causing the device to be removed from the network.
- The following is the method of performing a factory reset:
 1. Manual factory reset, via power cycle while holding button on inside lock escutcheon.
 - See the Lock Installation Manual for details.
 - Please use the manual factory reset procedure only when the network primary controller is missing or otherwise inoperable.

Supported Command Classes

The Yale Assure Z-Wave Plus™ deadbolts follow the Z-Wave™ Command Class Specifications for all command classes that are implemented. Please refer to these specifications for specifics on how each command class works. The supported command classes are listed below, and certain sections contain details about operations that may be specific to the Yale lock. If a section is blank, then please refer to the Z-Wave™ specifications.

As a secure device, most of the command classes supported by the lock are required to be sent securely with Z-Wave™ security. During enrollment, the controller can use the Security Command Class to get this list directly from the lock. If a command class requires security, it is also indicated as such below.

Specification used:

- sds12657-11_z-wave_command_class_specification_a-m
- sds12652-12_z-wave_command_class_specification_n-z

Command Class Z-Wave Plus™ Info, Version 2

The Z-Wave Plus™ Info command class reports the following information:

- Role Type: Slave Sleeping Listening (0x07)
- Node Type: Z-Wave Plus™ Node (0x00)
- Installer Icon Type: 0x0300
- User Icon Type: 0x0300

Command Class Manufacturer Specific, Version 2

The Manufacturer Specific command class reports the following information:

- Manufacturer ID: 0x0129
 - This is the manufacturer ID assigned to ASSA ABLOY.
- Product ID:
 - The Product ID can be used to differentiate between hardware platforms, as well as between ZW2 and ZW3. See Table 1 - First 2 Digits of Product ID, below, for details.
 - Product IDs for the locks covered in this document are as follows:
 - 0x05D1 for YRD410-ZW2 (2nd Generation Assure Keyed Push Button Deadbolt)
 - 0x05D2 for YRD420-ZW2 (2nd Generation Assure Keyed Touch Screen Deadbolt)
 - 0x05D3 for YRD430-ZW2 (2nd Generation Assure Keyless Push Button Deadbolt)
 - 0x05D5 for YRD450-ZW2 (2nd Generation Assure Keyless Touch Screen Deadbolt)
 - 0x05D1 for YRD614-ZW2 (2nd Generation Assure Keyed Push Button Deadbolt for PRO Customers)
 - 0x05D2 for YRD624-ZW2 (2nd Generation Assure Keyed Touch Screen Deadbolt for PRO Customers)
 - 0x05D3 for YRD634-ZW2 (2nd Generation Assure Keyless Push Button Deadbolt for PRO Customers)
 - 0x05D5 for YRD654-ZW2 (2nd Generation Assure Keyless Touch Screen Deadbolt for PRO Customers)
- Product Type ID:
 - 0x8104 for YRD410-ZW2, YRD420-ZW2, YRD430-ZW2, YRD450-ZW2, YRD614-ZW2, YRD624-ZW2, YRD634-ZW2 & YRD654-ZW2 (2nd Generation Assure Deadbolt)

Table 1 - First 2 Digits of Product ID

	Z-Wave™ Type			Platform				Hex Value	
	0	0	0	0	0	1	0		1
[0x8104]-ZW2	0	0	0	0	0	1	0	1	0x05
[0x8104]-ZW3	0	1	0	0	0	1	0	1	0x45

Command Class Security, Version 1

This command class has been implemented per the Z-Wave™ Specification.

Command Class Device Reset Locally, Version 1

The Yale door locks covered in this guide can be reset to their factory default settings by manually resetting the lock or by BLE command via app for BLE locks (by following the procedure outlined in the specific lock's manual).

Upon factory reset, all Z-Wave™ network settings are cleared, all the user codes are erased from the lock (including the master code), and all configurable settings are reset to default values, except for the language setting. A factory reset leaves the lock in a completely unsecure state (waiting for master code to be set), so care should be taken if using the configuration parameter to perform a remote reset. However, if the DUT is unenrolled/excluded from the network through the device menu mode, then the user code database and configuration settings will not be reset to the defaults.

Command Class Power Level, Version 1

This command class has been implemented per the Z-Wave™ Specification.

The Power Level command class was implemented to allow controllers to set the transmit power for the door lock. This could be useful in large networks with many nodes, so that the lock can find working routes back to the controller while transmitting at a lower power. This ensures robust routes when the normal transmit power level is restored.

Currently there is no way to initiate a low power enrollment; this command class can only be used once the lock is enrolled successfully.

Command Class Version, Version 2

The Yale Real Living locks are a multi-processor system with 1 additional firmware target. All processors can be updated through the Firmware Update Meta Data command class. The firmware targets are numbered as follows:

- Firmware Target 0 = Z-Wave™ Chip
- Firmware Target 1 = Lock Processor

To identify the firmware version for each target, the hex data in the firmware version report must be converted to decimal prior to combining major and minor version into the full version.

After a controller sends a Version Get command the log will display the Version Report similar to the below:

```
Send VERSION_GET to node 16 started
Send VERSION_GET to node 16 completed in 00:00:01.242
Rx [S2_ACCESS] VERSION_REPORT(86 12) + 03 07 10 02 22 02 01 2C 00
```

The above Version Report will be defined as this in the Z-Wave™ sniffer tool, Zniffer:

```
Command Class Version ver.3
Version Report
  Z-Wave Library Type:      0x03
  Z-Wave Protocol Version:  0x07
  Z-Wave Protocol Sub Version: 0x10
  Firmware 0 Version:      0x02
  Firmware 0 Sub Version:   0x22
  Hardware Version:        0x02
  Number of firmware targets: 0x01
  ▾ vg 1:                   2C 00
    Firmware Version:       0x2C
    Firmware Sub Version:   0x00
```

For Firmware Target 0, the Firmware 0 Version (0x02) and Sub version (0x22) translate to module firmware decimal value of "2.34".

For Firmware Target 1 (the data under vg1), Firmware Version (0x2C) and Sub version (0x00) translate to lock firmware decimal value of "4.3.00".

Command Class Battery, Version 1*

* This command class requires security.

Per the Z-Wave Plus™ Specification, the lock will send a Battery Report with a value of 0xFF to the Lifeline node when a critical battery level is reached (starting at about 4.2V for Product Type ID 0x8104). In addition, the Yale Locks provide 2 earlier low battery alarms through the notification command class (see Table 7 - Notification Table).

Low battery alarms will be generated if the lock is in a low battery state during one of the following events: any motor activation (keypad lock/unlock, RF lock/unlock, etc.), controller sends Get Battery command, or the unsolicited battery report was triggered. Yale locks will generate an unsolicited Battery Report at lock boot-up and every 8 hours if a node is listed in the Lifeline Group.

Command Class Door Lock, Version 2*

* This command class requires security.

Yale Z-Wave Plus™ locks support three door lock modes: Door Secured (0xFF), Door Unsecured (0x00), and Door Unsecured with timeout (0x01). When Auto Relock is enabled, the lock will automatically relock after all unlock events. Yale Z-Wave Plus™ locks do not support any of the “Door Unsecured for outside Door Handles” (0x20, 0x21) or “Door Unsecured for inside Door Handles” (0x10, 0x11) modes.

Command Class Door Lock Logging, Version 1*

* This command class requires security.

This command class has been implemented per the Z-Wave™ Specification.

Command Class Schedule Entry Lock, Version 3*

* This command class requires security.

Yale locks support Year Day Schedule types and Daily Repeating Schedule types. Yale locks allow the controller to apply multiple schedules to a single user. Each user has 1 Year Day Schedule slot (Slot ID 1) and 7 Daily Repeating slots (Slot IDs 1 – 7). If user scheduling is used in the lock, then the controller **MUST** set the lock’s time using the Time Parameters command class.

Command Class User Code, Version 1*

* This command class requires security.

Version 1 of this command class can address user code slots 1 through 250 via the User Code Set/Get/Report commands.

Table 2 – Expected Reports for Set/Get Commands

Command	Slots 1-250	Slot 251	Slots 252-254	Slot 255	Slots 256-500
User Code CC v1: User Code Get	User Code Report	User Code Report	User Code Report	User Code Report	N/A
User Code CC v1: User Code Set	User Code Report	Master Code Report	User Code Report	User Code Report	N/A

The master code can be accessed (read/write) using slot 251 (0xFB), if using version 1 of this command class.

Yale locks do not support bulk commands (setting or getting multiple user codes at once) or CRC functionality for this command class.

The following implementation notes apply specifically to non-access user codes:

- The usage of non-access users has changed slightly with ZW3, compared to ZW2, but is still backwards compatible. If a User Code Set is transmitted using version 1 of the command class, then the lock will accept a value of 0x04 as the status for the non-access user.
- A non-access user can be identical to a “normal” PIN code, aside from the fact that it does *not* grant access.
- Any available user code slot (except the master code) can be used to store non-access user code.
- Schedules can be applied to non-access users.

Yale locks support the following User ID Status values:

Table 3 - User ID Status User Code CC v1

User ID Status	User Code CC v1 Set	User Code CC v1 Report Value
<i>Description</i>	<i>Value</i>	<i>Value</i>
Available	0x00	0x00
Enabled / Grant Access	0x01	0x01
Disabled	0x02	0x03
	0x03	
<p>Messaging: The user code is accepted, but the lock does not grant access to the user. Instead, it generates an alarm to the Lifeline and does NOT take preventative actions for further attempts to enter the User ID and/or User Code.</p>	0x04	0x04
<p>One-Time Use: This PIN is disabled immediately after being used for a successful unlock operation.</p>	0x06	0x06
<p>Expiring: This PIN is disabled once a specified amount of time has passed after being used for a successful unlock operation. The expiration time is set through the Configuration command class.</p>	0x07	0x07

Command Class Time Parameters, Version 1*

* This command class requires security.

The controller must set the Time Parameters in the lock anytime the lock loses power. If the time is not set by the controller, then user codes with schedules applied to them cannot be granted access. When the lock is powered up, it will generate a Notification Report to indicate to the controller that power has been applied (Alarm V1 Type = 0x82, Alarm V1 Level = 0x00, Event Type = 0x08, Event Value = 0x01). This indicates to the controller that the lock no longer has a valid time set.

If the controller does not support either the Time CC or Time Parameters CC, then scheduled users will not have access.

Command Class Time, Version 2*

* This command class requires security.

The controller must set the Time Parameters in the lock anytime the lock loses power. Even though the Time CC is not secure, the Time Set command must be issued at the same or higher security level as when the device was enrolled for time to be set otherwise it will be rejected by the device. After 10 seconds from lock enrollment, if there are no messages from the controller the lock will initially request the Time (by sending Time Get and Time Parameter Get commands). If the time is not set by the controller, then user codes with schedules applied to them cannot be granted access. When the lock is powered up, it will generate a Notification Report to indicate to the controller that power has been applied (Alarm V1 Type = 0x82, Alarm V1 Level = 0x00, Event Type = 0x08, Event Value = 0x01). This indicates to the controller that the lock no longer has a valid time set.

If the controller does not support either the Time CC or Time Parameters CC, then scheduled users will not have access.

A time sync should occur every 8 hours, starting with the Time CC. If there is no response within a minute, the next step is to issue a Time Parameters Get to sync time.

Command Class Firmware Update Meta Data, Version 3*

* This command class requires security.

Yale Z-Wave Plus™ locks support over-the-air (OTA) upgrading of 2 firmware targets:

1. Firmware Target 0: Z-Wave™ chip
2. Firmware Target 1: The lock main processor

Firmware Target 0 is used to determine the correct Z-Wave™ processor image to download. Firmware Target 0 ID is always 0x0301, to signal this is a Z-Wave™ image.

Firmware 1 target will depend on which version of the lock is in use (mapped to the Product Type ID).

- For YRD410-ZW3, YRD420-ZW3, YRD430-ZW3, YRD450-ZW3, YRD614-ZW3, YRD624-ZW3, YRD634-ZW3 & YRD654-ZW3 (2nd Generation Assure Deadbolt), Firmware 1 ID = 0x8104

After an OTA is performed (a Firmware Update Status Report should return with successful), there is an additional step internally where we write/apply the image to the lock/module. When the image is being applied to the lock, the lock is unresponsive until completion of the applied image. Once the completion of the OTA image is applied the lock silently reboots.

Command Class Association, Version 2*

* This command class requires security.

This command class has been implemented per the Z-Wave™ Specification.

Command Class Association Group Info, Version 1*

* Command Class Requires Security

Yale locks support the Lifeline Association Group.

Table 5 - Association Table

Group ID	Maximum Nodes	Description	Commands
1	1	Lifeline	<ul style="list-style-type: none"> • Command Class Battery <ul style="list-style-type: none"> ○ Battery Report • Command Class Configuration <ul style="list-style-type: none"> ○ Configuration Report • Command Class Notification <ul style="list-style-type: none"> ○ Notification Report • Command Class Device Reset Locally <ul style="list-style-type: none"> ○ Device Reset Locally Notification

The following are the actions to trigger the reports:

Table 6 - Lifeline Report Trigger Table

Report Command	RF Trigger	Manual Trigger
Battery Report	Any RF Lock Operation when lock is under the battery thresholds	Any manual/keypad Lock Operation when lock is under the battery thresholds or Power Cycle Lock
Configuration Report	Configuration Set	Change Lock Settings via Keypad
Notification Report (Access Control)	Any RF Lock Operation	Manual or Keypad Unlock/Lock
Notification Report (Power Management)	Any RF Lock Operation when lock is under the battery thresholds	Any manual/keypad Lock Operation when lock is under the battery thresholds or Power Cycle Lock
Device Reset Locally Notification		HW Factory Reset

Command Class Notification, Version 4*

* This command class requires security.

Table 7 - Notification Table

Alarm Reports	Alarm type	Alarm Level	Description	Notification Type	Event
Deadbolt Jammed	0x09	0x01	Deadbolt jammed while locking	0x06	0x0B
		0x02	Deadbolt jammed while unlocking	0x06	0x0B
Keypad Lock	0x12	0x (01 - max users)	Where Alarm level represents user slot number	0x06	0x05
Keypad Unlock	0x13	0x (01- max users)	Where Alarm level represents user slot number (0x00 = Master Code)	0x06	0X06
Manual Lock	0x15	0x01	by key cylinder or inside thumb-turn	0x06	0x01
		0x02	by touch function (lock and leave)	0x06	0x01
		0x03	By inside button	0x06	0x01

Manual Unlock	0x16	0x01	By key cylinder or inside thumb turn	0x06	0x02
		0x02	By inside button	0x06	0x02
RF Operate Lock	0x18	0x01	by RF module	0x06	0x03
RF Operate Unlock	0x19	0x01	by RF module	0x06	0x04
Auto Lock Operate Locked	0x1B	0x01	Auto re-lock cycle complete, locked.	0x06	0x09
User deleted	0x21	0x (01-max users)	User was deleted. Alarm level = user slot number	0x06	0x0D (single)
		0xFF ¹	All User codes were deleted		0x0C (all)
Non-Access	0x26	0x (01-max users)	A Non-Access Code was entered at the lock. Where alarm level represents user slot number	0x06	0xFE
Door State / DoorSense™ 2	0x2B	0x00	Door is open	0x06	0x16
		0x01	Door is closed	0x06	0x17
		0x02	Door Propped (Door Open for longer than configurable door propped time)	0x06	0xFE

Daily Repeating Schedule Set/Erased	0x60	0x (01-max users)	Schedule(s) has been set/erased for specified user ID	0x06	0xFE
Daily Repeating Schedule Enabled/Disabled	0x61	0x (01-max users)	Daily Repeating Schedule(s) were enabled/disabled for User ID specified in Alarm Level. If Alarm Level = 0xFF then all users were affected.	0x06	0xFE
Year Day Schedule Set/Erased	0x62	0x (01-max users)	Schedule(s) has been set/erased for specified user ID	0x06	0xFE
Year Day Schedule Enabled/Disabled	0x63	0x (01-max users)	Year Day Schedule(s) were Enabled/Disabled for User ID specified in Alarm Level. If Alarm Level = 0xFF then all users were affected.	0x06	0xFE
All Schedule Types Erased	0x64	0x (01-max users)	All Schedule Types were Set (erased/set) for User ID specified in Alarm Level. If Alarm Level = 0xFF then all users were affected.	0x06	0xFE
All Schedule Types Enabled/Disabled	0x65	0x (01-max users)	Schedule(s) has been enable/disabled for specified user ID. If Alarm Level = 0xFF then all users were affected.	0x06	0xFE
Master Code changed	0x70	0x00	Master code was changed at keypad	0x06	0x12
		0xFB	Master code was changed via RF	0x06	0X0E
User added		0x (01-max users)	User added. Alarm level = user slot number	0x06	0X0E
Duplicate Pin code error	0x71	0x (01-max users)	Where Alarm level represents user slot Number, an Alarm is generated in response to add user via RF. This alarm is not generated when attempting to add duplicate pin at the Keypad (The lock simply denies it and plays the "Denied" sound.) Trying to duplicate the master code will result in a 0x71 0x00 alarm report.	0x06	0x0F

Door Lock needs Time set / RF Module Power Cycled	0x82	0x00	Power to the lock was restored and the locks RTC was cleared. The controller should set the time to ensure proper logging.	0x08	0x01
Disabled user entered at keypad	0x83	0x (01-max users)	A disabled user pin code was entered at the keypad	0x06	0xFE
Valid user but outside of schedule	0x84	0x (01-max users)	A valid user can be both a normal user and a non-Access user. If a non-access user is out of schedule this alarm will be sent instead of the non-access alarm.	0x06	0xFE
Tamper Alarm	0xA1	0x01	keypad attempts exceed code entry limit	0x06	0X10
		0x02	front escutcheon removed from main	0x06	0xFE
Low Battery Alarms ³	0xA7	0x (Current %)	<i>Low Battery</i> Starting at 4.6V	0x08	0x0A
	0xA8	0x (Current %)	<i>Critical Battery Level</i> Starting at 4.4V	0x08	0x0B
Integrated BLE Lock ⁴	0xE2	0x00	Integrated BLE Lock	0x06	0x03
		0x01	Integrated BLE Auto Relock	0x06	0x09
Integrated BLE Unlock ⁴	0xE3	0x00	Integrated BLE Unlock	0x06	0X04
		0x01	Integrated BLE Auto Unlock	0x06	0X04
Homekit BLE Lock ⁴	0xE4	0x00	Integrated Homekit BLE Lock	0x06	0x03
Homekit BLE Unlock ⁴	0xE5	0x00	Integrated Homekit BLE Unlock	0x06	0X04

¹ Deleting all user codes will also delete any associated schedules (year day and daily repeating scheduled pin codes) assigned to user codes.

² This requires additional Hardware and calibration within the Yale Access App.

³ The Yale lock also supports a 3rd low battery alarm: too low to operate. This alarm is sent out as a Battery Report (with value = 0xFF) through the Battery Command Class. This is the last low battery alarm level before the product stops functioning. Starting at 4.2V (0x8104)

⁴ Needs Yale Access App setup.

Command Class Configuration, Version 1*

* This command class requires security.

Table 8 - Configurable Parameters

Param. Num.	Name	Length	Configuration Properties			Info	Length of Info String (Max length allowed is 90)
			Min	Max	Default		
1	Volume	1 byte	0x01 (High Volume)	0x03 (Silent)	0x01 (High Volume) [0x8104]	Set Volume Level to high (1), low (2), or silent (3). [0x8104]	53
2	Auto Relock	1 byte	0x00 (Disable)	0xFF (Enable)	0x00 (Disable)	Set Auto Relock feature to enable or disable.	45
3	Relock time	1 byte	0x01 (1 seconds) ¹	0xB4 (180 seconds)	0x1E (30 seconds)	Adjust the time your lock will auto relock.	43

4	Wrong Code Entry Limit	1 byte	0x03	0x0A	0x03	Adjust the limit for wrong code entries allowed by your lock.	61
7	Shut down time	1 byte	0x0A (10 seconds)	0x84 (132 seconds)	0x3C (60 seconds)	Adjust the time your lock is shutdown after reaching its wrong code entry limit.	80
8	Operating mode ²	1 byte	0x00 (Normal Mode)	0x03 (Passage Mode) [0x8104]	0x00 (Normal Mode)	Set the Operating Mode to normal mode, keypad disable mode or passage mode.	76
11	One Touch Locking	1 byte	0x00 (Disable)	0xFF (Enable)	0xFF (Enable)	Set One Touch Locking feature to enable or disable.	51
13	Lock Status LED	1 byte	0x00 (Disable)	0xFF (Enable)	0x00 (Disable)	Set Lock Status LED feature to enable or disable.	49

18	Door Propped Timer ³	1 byte	0x00 (Disable) ⁴	0xFE (2540 seconds) ⁴	0x00 (Disable) ⁴	Adjust the time to receive an alert when the door is propped open.	66
19	DPS Alarms (DoorSense™) ³	1 byte	0x00 (Disable)	0xFF (Enable)	0xFF (Enable)	Enable or Disable DPS Alarms	28
28	Expiring Pin Code Enabled Time	1 byte	0x00 (Disable)	0xFF (127 Hours)	0x00 (Disable)	Timeout value used to determine time after first entry is triggered.	68

¹ Even though the lock accepts value 0x01 for Auto Relock Time, we limit the lock's minimum to value of 0x03. Therefore, if user tries to set Auto Relock Time to values 0x01 or 0x02, it will always report back value of 0x03.

² When Operation Mode feature is set to Passage Mode, this also results in disabling the following configuration parameters 2 (Auto Relock feature). The Passage Mode feature can only be set when user holds the inside button.

³ This requires additional Hardware and calibration within the Yale Access App.

⁴ The Door Propped value is represented as seconds X 10. (i.e., a value of 4 would mean a door propped timer of 40 seconds).

Yale Locks in Z-Wave 500 Series System Best Practices

Communication Signal Format

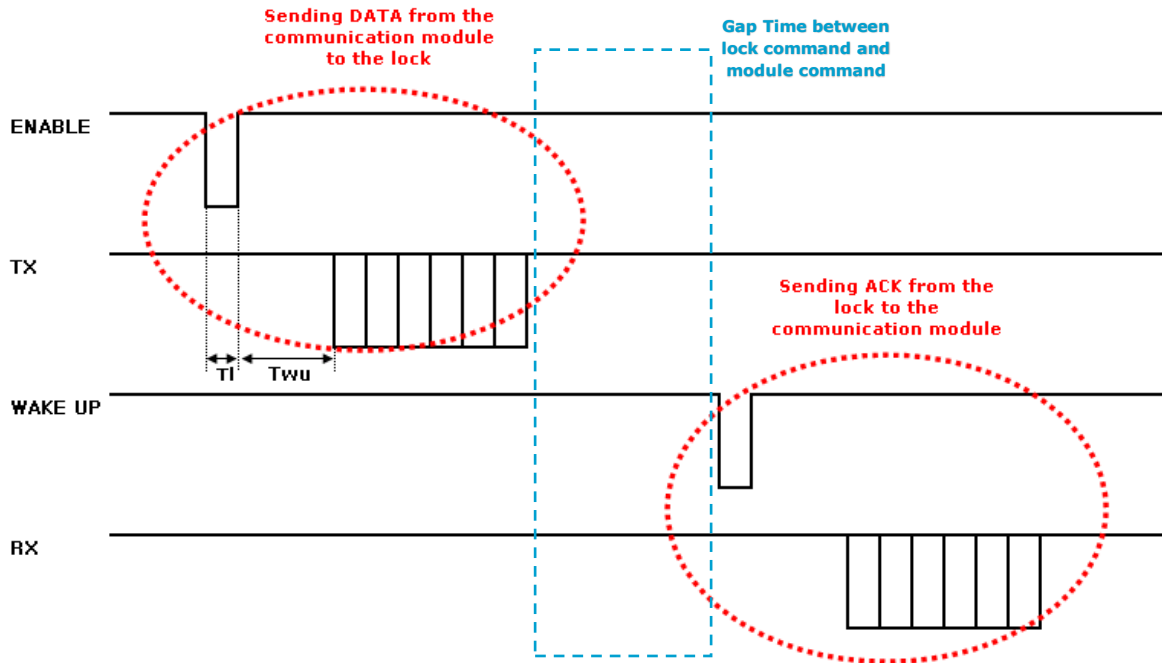

Figure 1: Signal Time Format

Data from the lock to Z-Wave 500 Series (ZW2) module takes 15 milliseconds.

Data from Z-Wave 500 Series (ZW2) module to the lock takes 272 milliseconds.

During the communication between the lock and module, the Z-Wave System must account for Gap time of 50 milliseconds which usually occurs when there is a configuration update, door lock state change, and user code being added/removed.

Commands Communication Timing

The following are the commands and total times that the Z-Wave System needs to be aware of when interacting with our ZW3 Locks before sending next commands:

Table 13 – Event vs Process Time

Commands/Events	TOTAL TIME
Door Lock Operation Get	287 milliseconds
Door Lock Operation Set (RF Unlock/Lock) ¹	2.674 seconds
Door Lock Operation Set -> Auto Relock ¹	5.011 seconds + Auto relock time.
Door Lock Operation Set (RF Unlock) -> Door Lock Operation Set (RF Lock) ¹	5.348 seconds
Manual Unlock via Thumb turn/ One Touch Lock via Keypad/ User Code Unlock/Lock ¹	337 milliseconds
User Code Get	287 milliseconds
User Code Set (Adding Single User Code) ²	674 milliseconds
User Code Set (Deleting Single User Code)	337 milliseconds
User Code Set (Deleting All User Codes)	1.724 seconds
Configuration Get (Single Parameter)	287 milliseconds
Configuration Set (Single Parameter) ³	674 milliseconds
Battery Get	287 milliseconds

¹ Our Motor operating time for moving deadbolts is 2 seconds.

² When multiple user codes are added in the Yale locks, an additional registration time of 230 milliseconds needs to be accounted for from User Code Set of Slot 1 to User Code Set of Lock's last slot.

³ When Configuration Parameter 8, Operation Mode feature, is set to value 3, Passage Mode, this also results in disabling the following configuration parameters 2 (Auto Relock feature). Therefore, Total Time will be 1.248 seconds. When Configuration Parameter 16, Escape Return Mode feature, is enabled, this also results in disabling the following configuration parameters 2 (Auto Relock feature) and 11 (One Touch Locking feature). Therefore, Total Time will be 1.872 seconds.



Assure Lock 2

Keyed YRD410 / YRD420

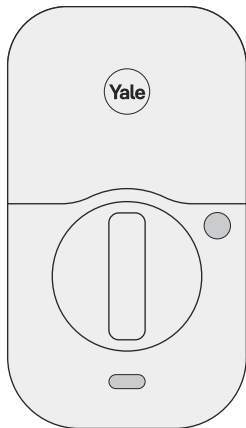

Download Yale Access App

Create an account if you don't already have one, and tap "Set Up a Device".

Note: If you have an account with the August App, use the same username and password for the Yale Access App.



Install Your Lock

Follow the step-by-step Installation Guide in this manual (pages 9-23), or refer to the app for installation instructions with helpful videos.

Note: If you use the app, please tear off the Door Checker and the Marking Template (pages 5-8) to use when prompted.

Set Up and Use Your Lock

Create permanent entry codes, issue entry codes for guests, operate your lock with your phone and more (pages 24-35).

Contents

In the Box	4	Using Your Lock	24
Door Checker	5	Connecting to Your Lock	25
Marking Templates	7	Creating and Managing Entry Codes	26
Installation Guide	9	Set Up HomeKit (Optional)	27
Remove Existing Deadbolt	10	LED Alerts	28
Check Door Measurements	11	Resetting Your Lock to Factory Defaults	29
Make or Adjust Holes	12	Features	30
Install Deadbolt Latch	13	App Settings	31
Install Exterior Keypad	14	Lock Operations Troubleshooting	33
Install Mounting Plate	15	Hardware Troubleshooting	35
Attach Wire Cable to Interior Lock	16		
Install Interior Lock	17		
Test Thumbturn and Key	18		
Install Yale Smart Module (Optional)	19		
Install DoorSense (Optional)	20		
Install Batteries and Replace Cover	23		

In the Box

Lock

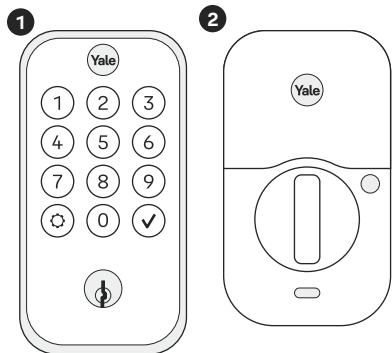

Add-Ons

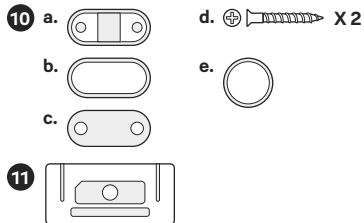

Hardware

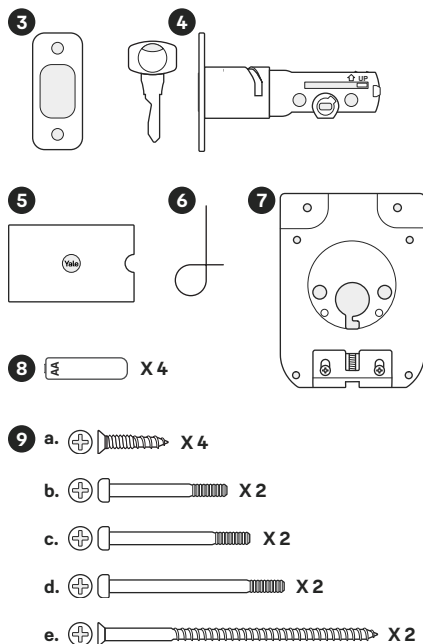

P/N YRD400-KD-0022 Rev B

1. Exterior Keypad
2. Interior Lock
3. Strike Plate
4. Adjustable Deadbolt & Key
5. Manual
6. Reset Pin
7. Mounting Plate
8. AA Batteries
9. Screws
 - a. Strike Plate and Deadbolt Screws
 - b. Teal Screw Set B
 - c. Black Screw Set C
 - d. Silver Screw Set D
 - e. Optional Security Strike Plate Screws
10. DoorSense
 - a. Housing
 - b. Cover
 - c. Mounting Tape
 - d. Screws
 - e. Flush Mount Cap
11. Smart Module
(Included with select models)

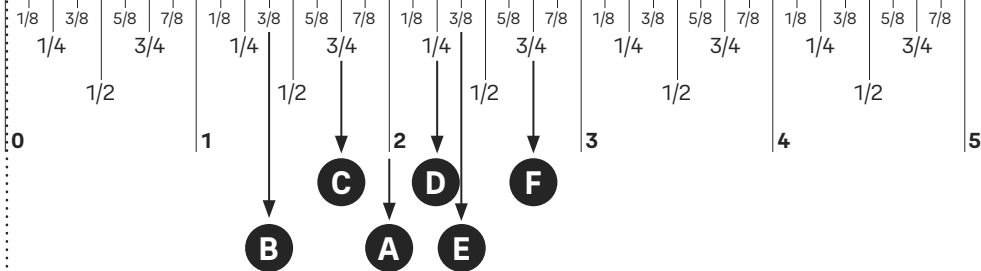

Door Checker Part 1

See Reverse for Part 2 →

Measure Clearance

- ✓ Greater than A
- ✗ Less than A
(Your door is not a match)

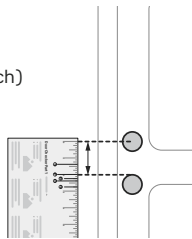

A. 2" minimum clearance between top of the door knob and center of deadbolt hole.

Measure Door Thickness

- ✓ B, C or D
- ✗ Less than B or greater than D
(Your door is not a match)

- B.** 1-3/8" door thickness; use **teal** (shortest) **screws**.
- C.** 1-3/8" - 1-3/4" door thickness; use black (medium) **screws**.
- D.** 1-3/4" - 2-1/4" door thickness; use **silver** (longest) **screws**.

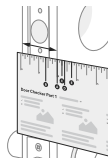

Measure Backset

- ✓ Equals E or F
- ✗ Doesn't equal E or F
(Your door is not a match)

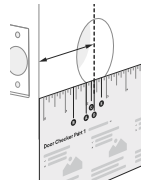

- E.** 2-3/8" backset, use out of box latch setting.
- F.** 2-3/4" backset, adjust latch setting (Step 2, point 1 of this manual).

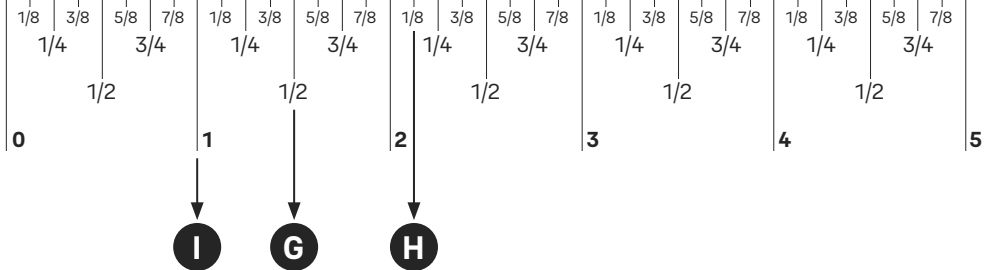

Door Checker Part 2

See Reverse for Part 1 →

Measure Face Bore

- ✓ Equals G or H
- ✎ Less than G
(Adjust diameter to G or H)
- ✗ Greater than H
(Your door is not a match)

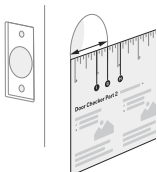

Measure Edge Bore and Strike Pocket

- ✓ Equals I
- ✎ Less than I
(Adjust diameter to I)
- ✗ Greater than I
(Your door is not a match)

Door (Edge Bore)

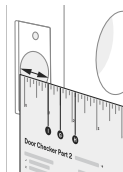

Frame (Strike Pocket)

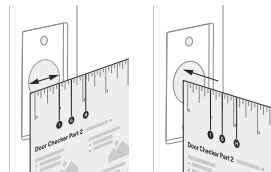

Diameter

Depth

- G.** 1-1/2" face bore diameter.
- H.** 2-1/8" face bore diameter.

- I.** 1" edge bore diameter;
1" strike pocket diameter and depth.



Minimum strike pocket depth is 1".

Tear Along the Dotted Line

Marking Template for 2-1/8" (54mm) Face Bore

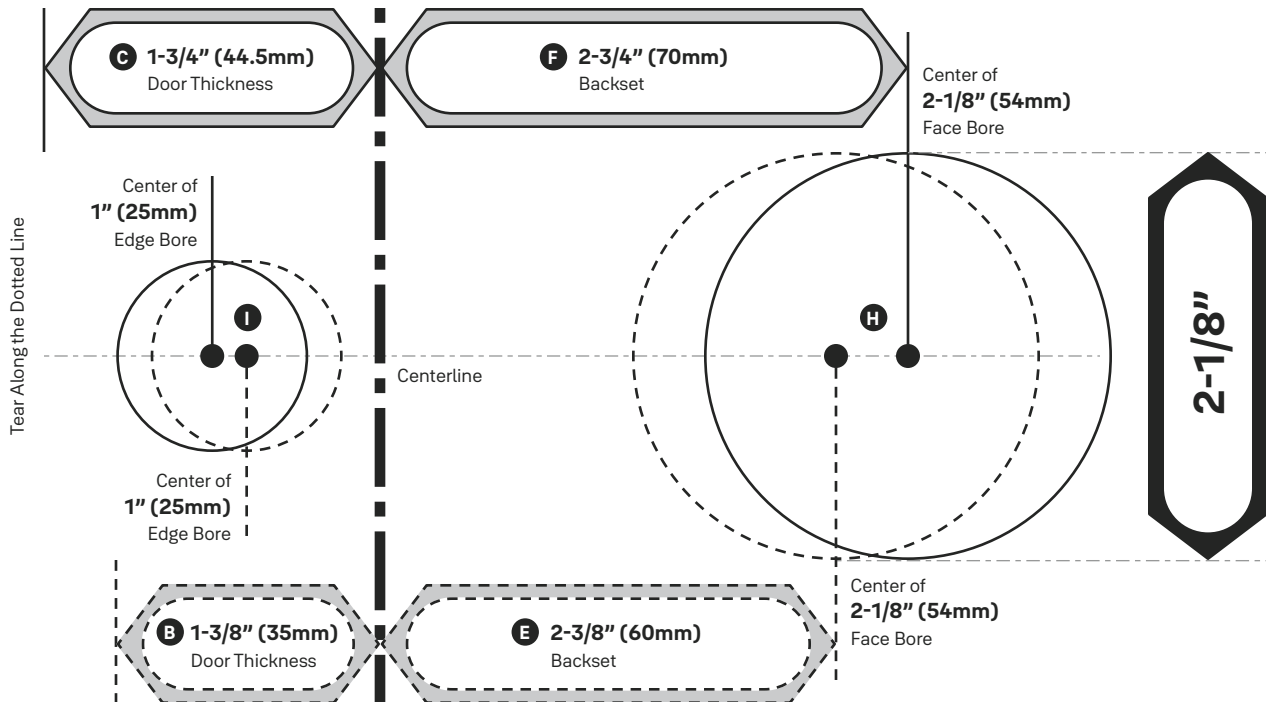

Marking Template for 1-1/2" (38mm) Face Bore

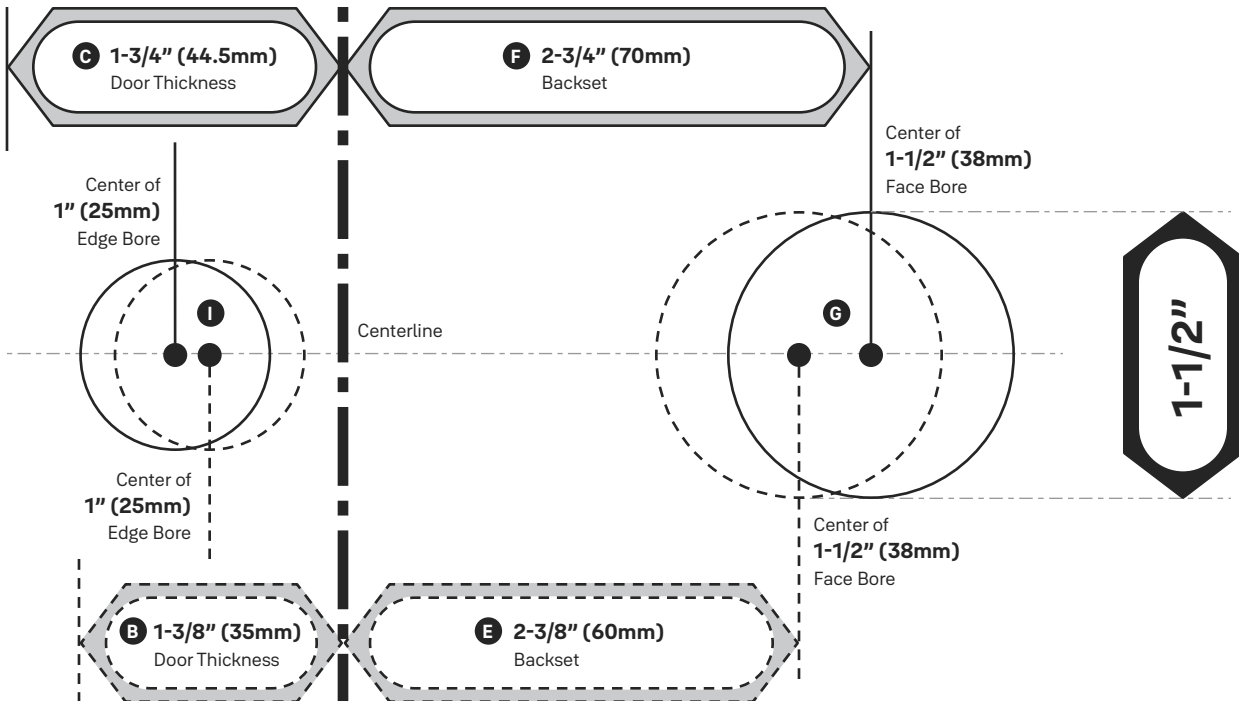

Installation Guide

Required Tools

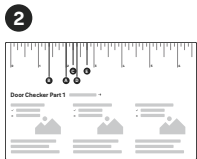
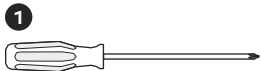

You Might Also Need

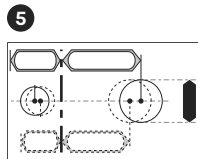
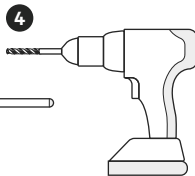
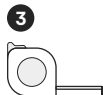

1. **Phillips Head Screwdriver**
2. **Door Checker**
(tear off pages 5-6 of this manual)
3. **Tape Measure**
4. **Drill**
5. **Marking Template**
(tear off pages 7-8 of this manual)
6. **Pencil**
7. **Wood Mortise Chisel**
8. **Utility Knife**
9. **Level**



Failure to follow the Installation Guide precisely could result in damage to the product, voiding the factory warranty, and could lead to failure of the product to provide access.

1a Remove Existing Deadbolt

If you have a new door, please proceed to step 1b. →

If you have a deadbolt on your door, use the diagram to help you remove it.

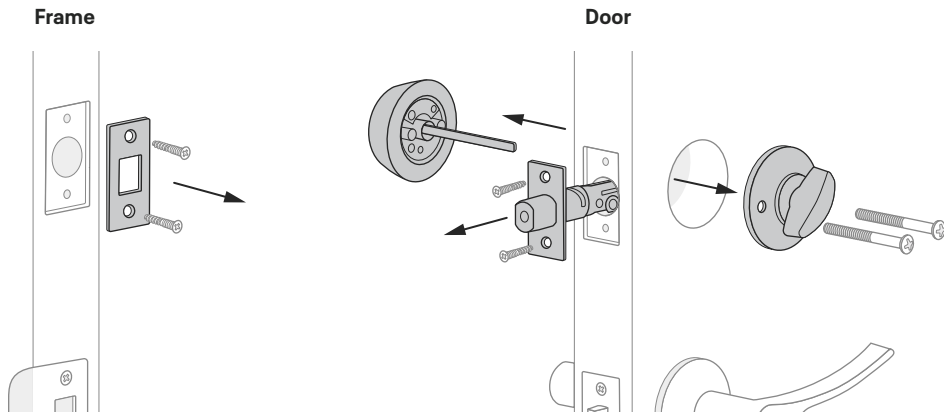

Keep your old deadbolt until your new lock has been successfully installed.

1b Check Door Measurements

If your door doesn't have holes, please proceed to step 1c. →

Tear off the **Door Checker** (pages 5-6) and follow the guidelines on **both sides** to measure each aspect of your door and frame. There are some cases when existing holes cannot be adjusted to be compatible.

✎ If you need to make adjustments, go to **step 1c** and find the closest match to each aspect of your door on the **Marking Template**.

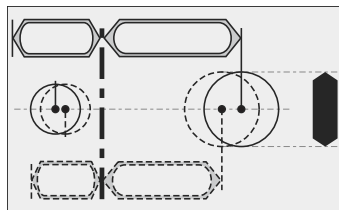
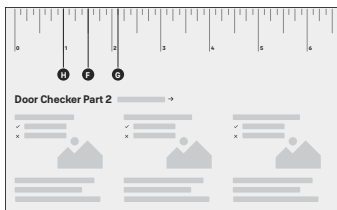
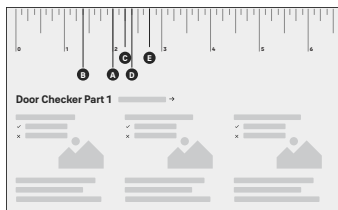

⚠ Please do not drill any holes until you confirm that your door is compatible.

If you have confirmed that the existing holes are compatible with your new lock, please proceed to step 2 (skip step 1c).

1c Make or Adjust Holes

Skip this step if you have confirmed that the existing holes are compatible (step 1b).

1. Tear off the **Marking Template** (pages 7-8), and choose the preferred face bore diameter (**2-1/8"** or **1-1/2"**) on either side of the template.
2. Tape the Marking Template onto the door as shown.
3. Check the door thickness. It should match either the shape with **solid** outlines (**1-3/4"**), or the one with **dashed** outlines (**1-3/8"**).
 - 3a. Use **solid** lines as a template for **1-3/4"** door thickness.
 - 3b. Use **dashed** lines for **1-3/8"** door thickness.
4. Choose your preferred backset. It should match either the shape with **solid** outlines (**2-3/4"**), or the one with **dashed** outlines (**2-3/8"**).
 - 4a. Use **solid** lines as a template for **2-3/4"** backset.
 - 4b. Use **dashed** lines for **2-3/8"** backset.
5. Drill holes in your door where marked.

6. On the door frame, align the center of the strike plate with the center of the edge bore. Trace the strike plate, then chisel to the depth of the strike plate so it sits flush with your door frame. Drill the **1"** diameter strike pocket with a minimum depth of **1"**.

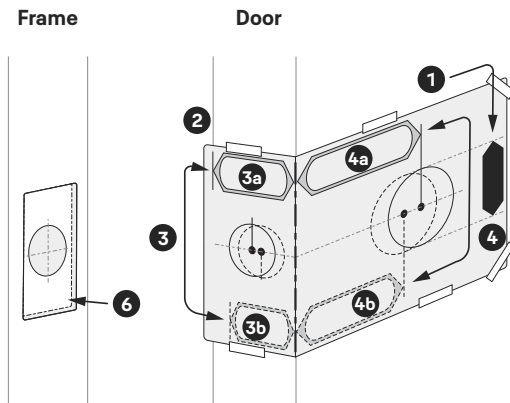

2 Install Deadbolt Latch

1. Correct deadbolt length is based on the backset. Refer to measurements **E** and **F** on the **Door Checker** (page 5) to verify backset.

E 2-3/8" Backset (Out of box)

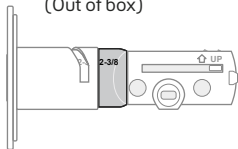

F 2-3/4" Backset (To adjust, twist neck by holding the body stable)

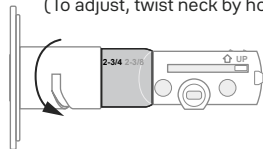

! Minimum strike pocket depth is 1".

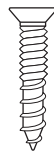

x 2 for Deadbolt Latch
x 2 for Strike Plate
(Actual size)

2. Align strike plate with deadbolt latch.
 - 2a. (Optional) Security screws can be used in place of the small strike plate screws.
3. Make sure UP arrow on the deadbolt is facing upwards.
4. Deadbolt latch must be in an unlocked position.

Note: If the deadbolt latch is extended, use a small flathead screwdriver to rotate slot until deadbolt latch is retracted.

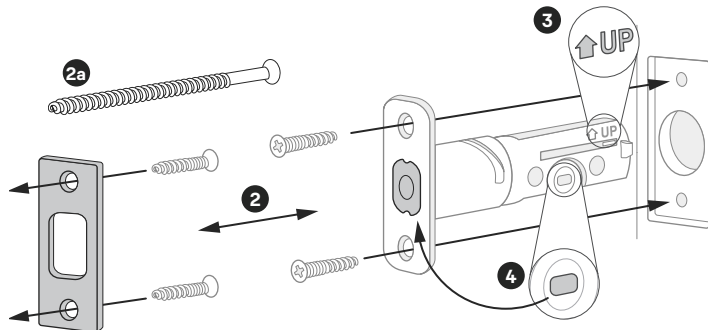

3 Install Exterior Keypad

1. Refer to measurements **G** and **H** on the **Door Checker** (page 6) to measure face bore hole. If the hole is **1-1/2"** (**G**), unscrew the two small screws and remove the adapter.

⚠ **Install your lock with the door open.**
Do not close your door until all the steps are completed.

2. Make sure your deadbolt latch is in an unlocked position. Refer to **step 2, point 4** (page 13) for guidance on how to retract it, if needed.
3. Slide the tailpiece through the deadbolt latch slot, making sure the keypad is on the exterior part of your door.
4. Guide the wire cable under the deadbolt.
5. Slide the keypad in place. Hold or secure in place until the mounting plate is installed in the next step.

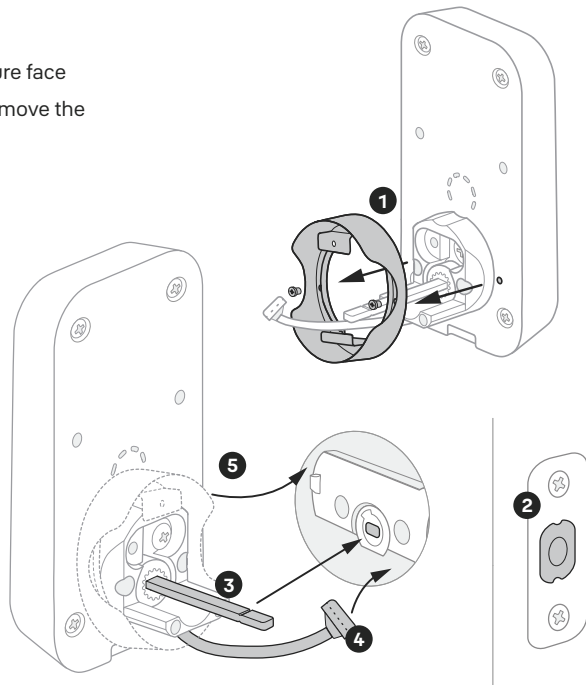

4 Install Mounting Plate

1. Refer to measurements **B**, **C**, and **D** on the **Door Checker** (page 5) to select screws.



2. Route the wire cable into the designated slot in the mounting plate.
3. Guide posts of the mounting plate into the holes on the exterior keypad.
4. Slide tailpiece through the designated slot in the mounting plate.
5. Tighten screws with a screwdriver to secure the mounting plate. As you tighten the screws, make sure the mounting plate and the keypad are straight.



Ensure that the wire cable is not pinched to prevent it from reducing your lock's battery life.

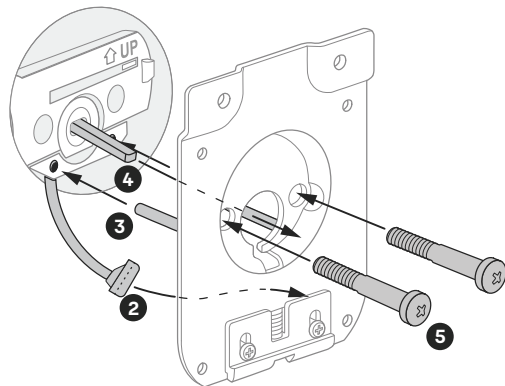

5 Attach Wire Cable to Interior Lock

1. Remove battery cover by pulling it upwards off the body of the interior lock.

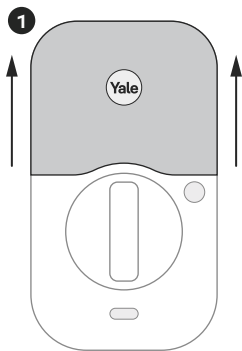

2. Make sure the side of the cable end with the ridges and the marked line faces outward.
3. Push cable into the designated slot until you hear a click.

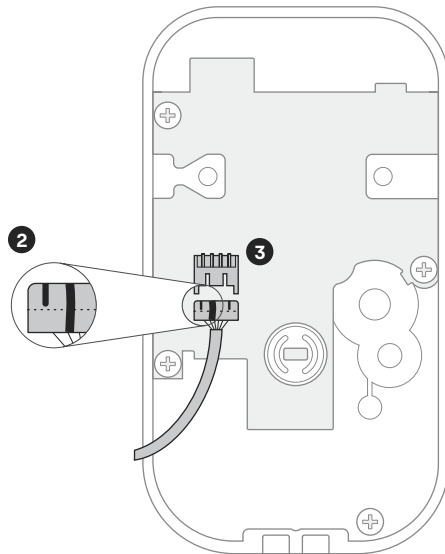

6 Install Interior Lock

1. Make sure the tailpiece slot is in horizontal position. Use the thumbturn to adjust if needed.
2. Slide the tailpiece through the designated slot on the back of the thumbturn.
3. Press the lock against the mounting plate, adjusting its position until it clicks into place and the bottom of the lock is held in place.
4. Tighten the two pre-installed screws.

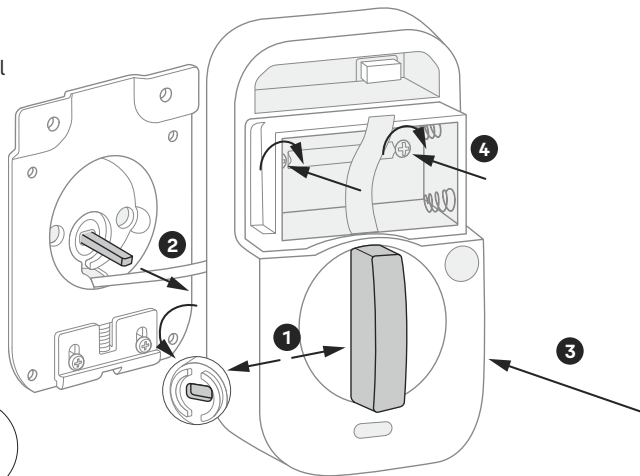

⚠ When fully tightened, lock should be flush to door.

7 Test Thumbturn and Key

If deadbolt latch does not lock or unlock with the **key** (from the outside) or the **thumbturn** (from the inside):

- Ensure that the deadbolt latch is centered in the face bore hole;
- Ensure that the tailpiece is positioned horizontally and inserted through deadbolt latch slot (**step 3, point 3**) into the thumbturn slot (**step 6, point 2**).



⚠ Smooth deadbolt latch operation will enhance your battery life.

8 Install Yale Smart Module (Optional)

If your lock model does not include a Smart Module, please proceed to step 9a. →

Insert Yale Smart Module into the designated slot at the top of the body of the lock.

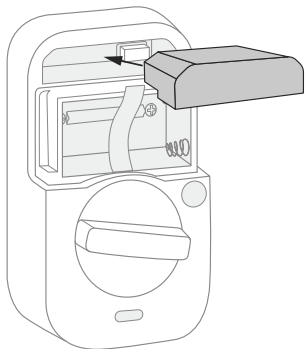

Note: If you purchased your module separately, check compatibility with your Assure 2 Lock. See table below for the list of compatible modules.

AYR-MOD-ZWV-USA

Z-Wave 500 series Module

AYR-MOD-WF1-USA

Wi-Fi Module



Batteries must **not** be installed when inserting or removing Yale Smart Module.

9a Install DoorSense (Optional)

If you do not wish to install DoorSense, please proceed to **step 10.** →

DoorSense is a magnetic sensor installed on your door frame that can keep track of when the door is opened and closed.

For **surface mount** instructions, please proceed to **step 9b.** →

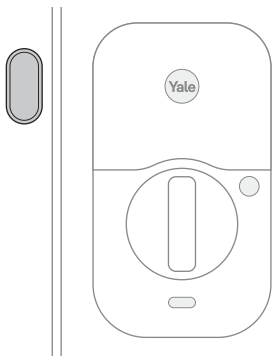

Surface mount is a quick and easy option to secure DoorSense next to your lock. For this method the door must be flush with the frame.

For **flush mount** instructions, please proceed to **step 9c.** →

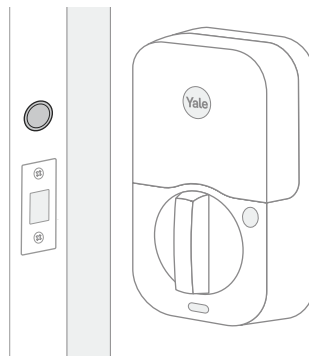

Flush mount is installing DoorSense into the edge of the door frame. It provides a cleaner look with more robust performance but requires drilling.

9b DoorSense Surface Mount

1. Remove one side of the backing from the adhesive.
2. Attach tape to the back of the DoorSense, ensuring it is aligned with the edges of the device and the screw holes.
3. Remove the remaining backing from the adhesive.
4. Determine mounting location. For optimal performance, DoorSense should be mounted within 1-1/2" from the edge of your door frame.
5. Ensure DoorSense is in proper position by center aligning it with the Yale logo on the battery cover, and adhere it to the door frame.
6. Tighten pre-installed screws and attach cover.

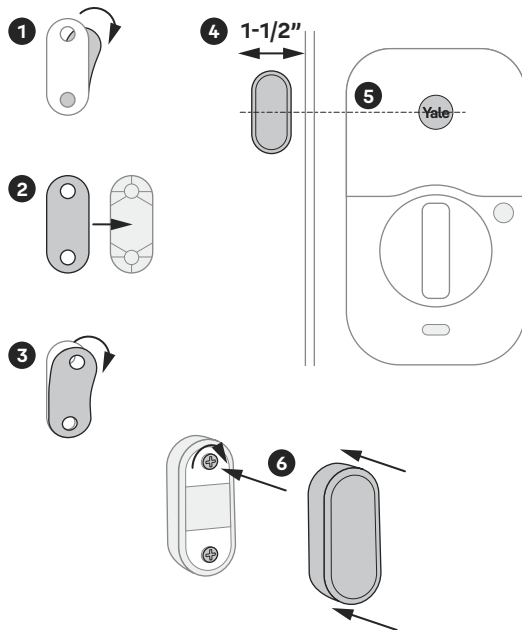

It is recommended to complete the last step after your lock is calibrated with the app to ensure you are able to retrieve accurate door state readings before modifying your frame.

9c DoorSense Flush Mount

1. Take off DoorSense cover.
2. Push the magnet out of the housing.
3. Expose the adhesive on the magnet cap by removing the blue backing.
4. Press the magnet onto the cap so that the notches interlock.
5. Determine mounting location on the door frame. The distance from the center of the strike plate to the center of the DoorSense should be 2", making it in line with the logo on the battery cover of the lock.
6. Mark a hole that's horizontally centered on the door frame and is 5/8" in diameter.
7. Drill a 1/2" deep hole where marked.
8. Insert DoorSense into the hole.

Note: If it is too snug to push in by hand, protect the frame with a piece of scrap wood and use light blows with a hammer or mallet.

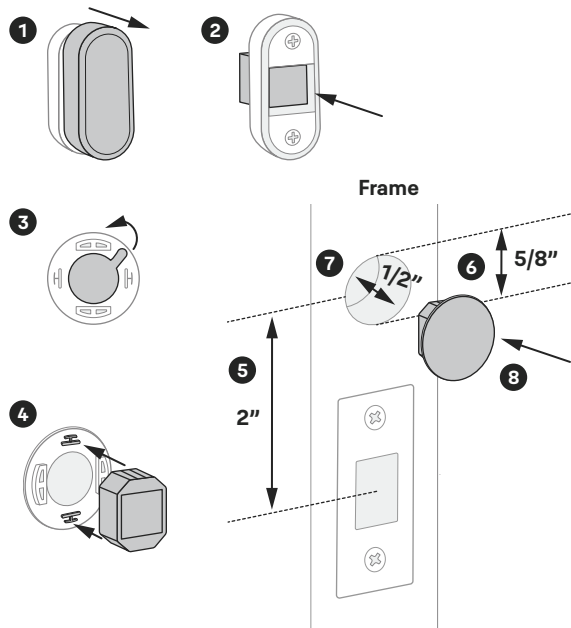

10 Install Batteries and Replace Cover



Make sure you have Yale Access App downloaded and an account created.

Once batteries are inserted, lock is ready to be set up with the app.



1. Before installing batteries, make sure the deadbolt latch is unlocked.
2. Place ribbon behind batteries for easy battery removal.
3. Install 4 batteries.
4. Replace cover.

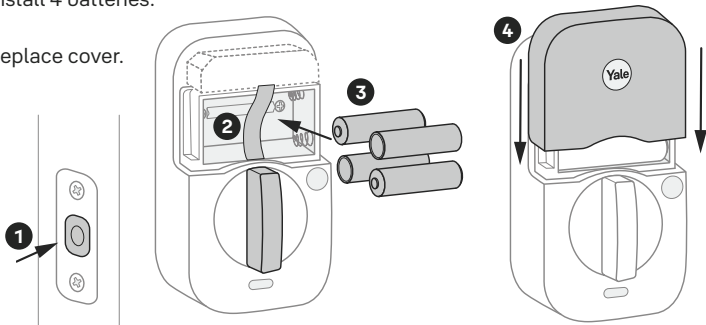

P/N YRD400-KD-0022 Rev B

5. Once batteries are inserted, the entire keypad will light up in a clockwise pattern. Once this happens, the lock is in pairing mode. Open Yale Access App, tap on "Set Up a Device", and follow the in-app setup instructions.

Note: If the lock exits pairing mode, simply press the Yale logo to restart.

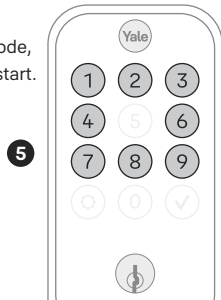

Using Your Lock

Exterior Keypad

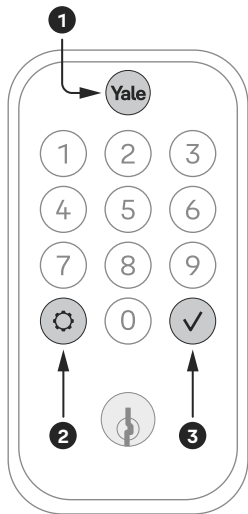

To **lock** your door

Press 

To **unlock** your door

Press  →

Enter entry code →

Press 

Interior Lock

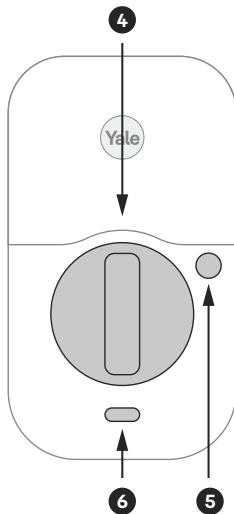

1. Wake / One-Touch Locking
2. Warnings / Menu
3. Submit Entry Code
4. Thumbturn
5. Passage Button
6. Interior LED Indicator

Connecting to Your Lock

There are two possible ways to connect to your lock with your Yale Access app. When you're near your lock you can connect through Bluetooth, and if you have an optional module you can connect remotely through Wi-Fi.

With **Bluetooth** connection, you can use your app to lock, unlock, create or manage entry codes, change settings, see who used the lock, etc. **while you're within Bluetooth range of the lock.** Every Assure Lock 2 has Bluetooth built in.

With **Wi-Fi** connection, **you can be away from home** and use your app to operate your lock, monitor who's coming and going, and create or manage entry codes. To connect your lock to your Wi-Fi network, you will need a module (available with select models and sold separately). See **step 8** for compatible modules.

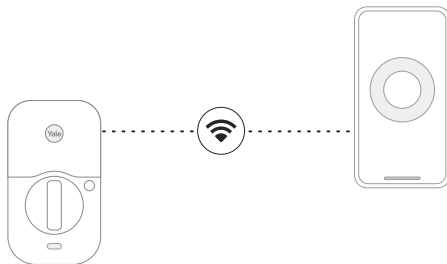
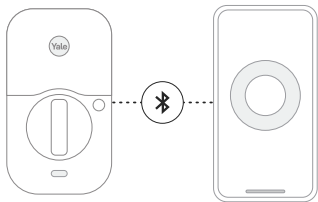

Creating and Managing Entry Codes



You must have Bluetooth or Wi-Fi connection with the lock to create or manage entry codes.

Your changes will be pending until you do have connection with the lock.

You can create and manage entry codes from the Guest List tab of the Yale Access app.

1. To create a code for a new user, tap on "Invite", then select whether they should also have app access or only entry code access. While inviting them, you will be able to create an entry code.
2. Tap on existing users in Guest List to create new entry codes for them or manage existing ones.

Set Up HomeKit (Optional)

⚠ Apple HomeKit is an iOS feature and is not available for Android.

Enabling HomeKit integration allows you to connect your lock and control it from your iPhone with the Apple Home app.

1. To enable HomeKit make sure your lock is installed and set up with Yale Access app. In the Yale Access app lock settings select "HomeKit" to begin HomeKit setup.
2. During setup, you will need access to the HomeKit code located on the side of the lock under the battery cover.

Note: if you have HomePod®, HomePod Mini®, or Apple TV® set up as a home hub, to ensure successful HomeKit setup, make sure they are online and connected.

3. Follow instructions in the Yale Access app to set up HomeKit.

Note: Controlling this HomeKit-enabled accessory automatically and away from home requires a HomePod®, HomePod mini®, or Apple TV® set up as a home hub.

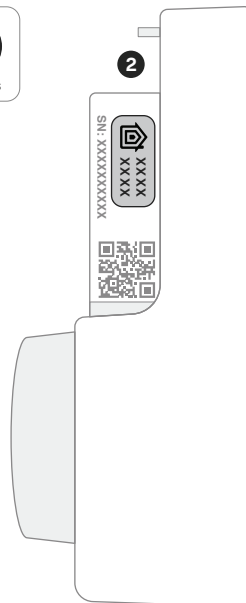

Exterior Keypad Alerts

Gear flashes amber	Low battery level 1
Gear flashes red	Low battery level 2
Gear flashes red, then stays red	Low battery level 3
Checkmark flashes	Pairing success
Any key, then gear flash red	Jammed lock
Gear flashes white	Pairing
Gear flashes red during pairing	Pairing failure



Interior Lock Alerts

LED indicator flashes blue	Low battery levels 1, 2, and 3
LED indicator flashes red	Locked state
LED indicator flashes green	Unlocked state
LED indicator turns green for 3 seconds	Pairing success
LED indicator turns red for 3 seconds	Pairing failure
LED indicator intermittently flashes yellow	Passage Mode is on (see page 30)

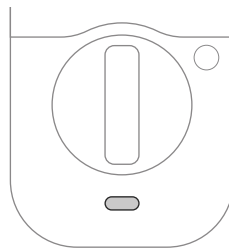

Resetting Your Lock to Factory Defaults



If you have set up your lock with Yale Access App, you should reset it using the app.

Go to your lock's settings and choose "Factory Reset".



1. Remove one battery.
2. Insert reset pin into the designated reset hole.
3. Press and hold the reset pin.
4. While holding the reset pin, reinsert battery.
5. Keep holding the reset pin for 5 more seconds.
6. Take out the reset pin.

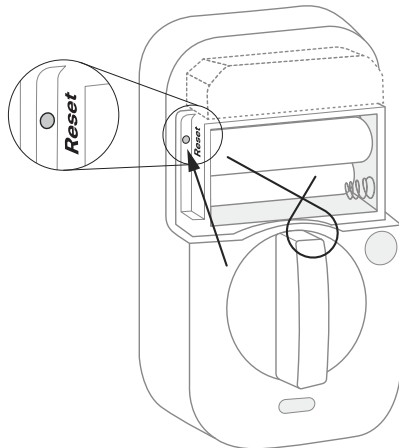

DoorSense	<ul style="list-style-type: none">• DoorSense keeps track of when your door is closed or open.
Entry Codes	<ul style="list-style-type: none">• Entry codes are used to unlock your door.• Create entry codes from the "Guest List" tab in the Yale Access App.• You can set permanent, recurring, and temporary entry codes.• An unlimited number of entry codes can be created or deleted as long as you have Bluetooth or Wi-Fi connection to the lock.
Auto-Lock	<ul style="list-style-type: none">• Auto-Lock automatically locks the door for you.• It can be set to lock on a timer for as short as 30 seconds, or as long as 30 minutes.• When using the Auto-Lock feature with DoorSense, your door will not lock until it is closed.• Auto-Lock can be set up in the lock settings of the app.
Auto-Unlock	<ul style="list-style-type: none">• Auto-Unlock knows when you arrive and unlocks the door as you approach.• Auto-Unlock can be set up in the lock settings of the app.
Passage Mode	<ul style="list-style-type: none">• Use passage mode when you want to disable Auto-Lock for an extended period of time.• Simply press and hold the Passage button on the inside of the lock until you hear a chime to turn it on.• To turn passage mode off, lock your door or press and hold the Passage button until you hear a chime.
Integrations	<ul style="list-style-type: none">• Yale Access products work in harmony with some of your favorite smart home brands.• Integrations can be set up in the Yale Access App from the "Works With" menu option.

App Settings

You can find these and other settings in the **Yale Access App**.

Security

Hide Entry Codes

If turned on, all entry codes within the app will be hidden from view.

Verified Access

If turned on, biometric/passcode authentication is required to operate the lock using the app.

Notifications

Smart Alerts

Create alerts you wish to receive from the app.

Automation

Auto-Lock

Door will automatically lock, either when door is closed (with DoorSense), or on a timer.

Auto-Unlock

Door will automatically unlock when you arrive home.

DoorSense

Allows you to know when your door is opened or closed.

Information

Programming Code

This code is automatically created by the Yale Access App and used to access programming features: handing, Smart Module integration, and diagnostics. This code cannot be used to unlock the door. Find your programming code in the Yale Access App, enter this code on the keypad and press the gear symbol.

App Settings

You can find these and other settings in the Yale Access App.

Advanced Device Settings

Device Settings	Volume	You can turn the lock volume on or off, and set it to high or low.	
	Inside Indicator Light	When turned on, it will show the active status (e.g. locked) of the lock. This light will also inform you when the batteries are low, passage mode is enabled, and pairing is successful.	
	One-Touch Locking	Lock the keypad by touching the Yale logo. This feature is on by default and can be turned off in settings.	
Keypad Settings	Keypad Security	Shutdown Timing (Default: 60 sec)	The lock will shut down for the set period of time and not allow operation after the wrong code entry limit has been reached.
		Wrong Code Limit (Default: 5 times)	After the set number of unsuccessful attempts at entering a valid entry code, the lock will shut down and not allow operation for 60 seconds.
	Operating Mode	Normal (Default)	All entry codes will work and the lock can be unlocked and locked using the app and voice assistants.
		Vacation	When enabled, all entry code access will be restricted. Users can still lock and unlock the door with the app.

Lock Operations Troubleshooting

Lock does not respond.	<ul style="list-style-type: none">• Press the Yale logo to activate the keypad.• Verify contact with the logo.• If keypad numbers are visible, check if they respond when pressed.• Check batteries are installed and oriented correctly in battery case. Replace batteries* if needed.• Check that the keypad wire is fully connected and not pinched.
Lock does not respond – door is locked and inaccessible.	<ul style="list-style-type: none">• Batteries may not have enough power. Replace batteries*.• Use mechanical key to unlock the door.
Lock is on for a while then shows no reaction. Lights dim.	<ul style="list-style-type: none">• Batteries do not have enough power. Replace batteries*.
Lock chimes indicating code acceptance but door will not open.	<ul style="list-style-type: none">• Check for any foreign objects between door and frame.• Check that the wire is firmly connected to the interior lock.
Lock operates to allow access but will not automatically unlock.	<ul style="list-style-type: none">• Check to see if Auto-Lock is enabled.• Disable Auto-Lock to lock the door manually.
Lock responds “Low Battery”.	<ul style="list-style-type: none">• Replace all four (4) batteries* with new AA alkaline batteries.

* After replacing your batteries, it's highly recommended to use your app to lock or unlock your device. This will allow the app to connect to the lock to ensure that the internal time of the device is correct.

Entry code will not register.	<ul style="list-style-type: none">• If low battery indicator is lit, replace batteries*.• Verify that your entry code consists of 4 to 8 digits.• Make sure you are using different entry codes for different users.• Entry code must be entered while the keypad is active (tap on the Yale logo to wake it up and enter the entry code within 5 seconds).
Upon entering an entry code and pressing the Check key, the lock displays "Invalid Code" error or lock times out without responding.	<ul style="list-style-type: none">• Verify entered code is a valid, previously programmed, 4 to 8 digit code.• Vacation mode might be on. Only an admin user can switch vacation mode to normal in the app.
Upon entering an entry code and pressing the Check key, lock responds "Wrong Number of Digits".	<ul style="list-style-type: none">• The digits entered were incorrect or incomplete. Re-enter the correct code followed by the Check key.
Deadbolt does not extend when locking the door with the keypad.	<ul style="list-style-type: none">• Lock was not handed properly. Find the setting called "Lock Handing" to fix this issue.
Lock operates but makes no sound.	<ul style="list-style-type: none">• Check in the app settings if volume is set to off.

* After replacing your batteries, it's highly recommended to use your app to lock or unlock your device. This will allow the app to connect to the lock to ensure that the internal time of the device is correct.

Deadbolt grinds and will not extend to lock when using an entry code but thumbturn locks and unlocks smoothly.	<ul style="list-style-type: none">• Lock was not handed properly. Find the setting called "Lock Handing" to fix this issue.
Deadbolt is hitting the strike plate.	<ul style="list-style-type: none">• Reposition the strike plate to align with deadbolt.
Deadbolt is not fully extending.	<ul style="list-style-type: none">• Increase depth of the deadbolt strike pocket in the frame.
Resistance when locking deadbolt that requires pushing or pulling on the door to align deadbolt and latch.	<p>Adjust your existing knob, lever, or handleset strike plate. Latch engagement into the strike is the main component used for door alignment.</p> <p>To adjust knob / lever / handleset strike plate:</p> <ol style="list-style-type: none">1. Remove plate from door frame with a hand screwdriver. Note: Using an electric driver may strip screw heads or enlarge screw holes.2. Locate tab on strike plate. Bend the tab towards surface of strike. Note: A small change may be all that is required.3. Reinstall strike plate using a screwdriver and test again.4. If door cannot be adjusted sufficiently with strike tab, both knob/lever/handleset latch and deadbolt could require adjustment – we suggest you contact a local locksmith for assistance. <p>For help with misalignments, watch our door alignment video: US.YaleHome.com/Support</p>

FCC:

FCC ID: 2ABFG-YRD420BLEV1

IC ID: 11626A-YRD420BLEV1

Class B Equipment

This equipment has been tested and found to comply with the limits for a Class B digital device, pursuant to Part 15 of the FCC Rules. These limits are designed to provide reasonable protection against harmful interference in a residential installation. This equipment generates, uses, and can radiate radio frequency energy and, if not installed and used in accordance with the instructions, may cause harmful interference to radio communications. However, there is no guarantee that interference will not occur in a particular installation. If this equipment does cause harmful interference to radio or television reception, which can be determined by turning the equipment off and on, the user is encouraged to try to correct the interference by one or more of the following measures:

- Reorient or relocate the receiving antenna.
- Increase the separation between the equipment and receiver.
- Connect the equipment into an outlet on a circuit different from that to which the receiver is connected.
- Consult the dealer or an experienced radio/TV technician for help.

•
"This product can be operated in any Z-Wave network with other Z-Wave certified devices from other manufacturers. All mains operated nodes within the network will act as repeaters regardless of vendor to increase reliability of the network."

Warning:

Changes or modifications to this device, not expressly approved by **Yale Home** could void the user's authority to operate the equipment.

Industry Canada:

FCC ID: 2ABFG-YRD420BLEV1

IC ID: 11626A-YRD420BLEV1

This Class A digital apparatus meets all requirements of the Canadian Interference Causing Equipment Regulations.

Yale Home24/7 Support: 1-855-213-5841 • [Support.ShopYaleHome.com](https://www.Support.ShopYaleHome.com)

Yale® and Assure Lock® 2 are registered trademarks of Yale Home. Other products' brand names may be trademarks or registered trademarks of their respective owners and are mentioned for reference purposes only. ©Copyright 2023. All rights reserved.

Reproduction in whole or in part without the express written permission of Yale Home is prohibited.