

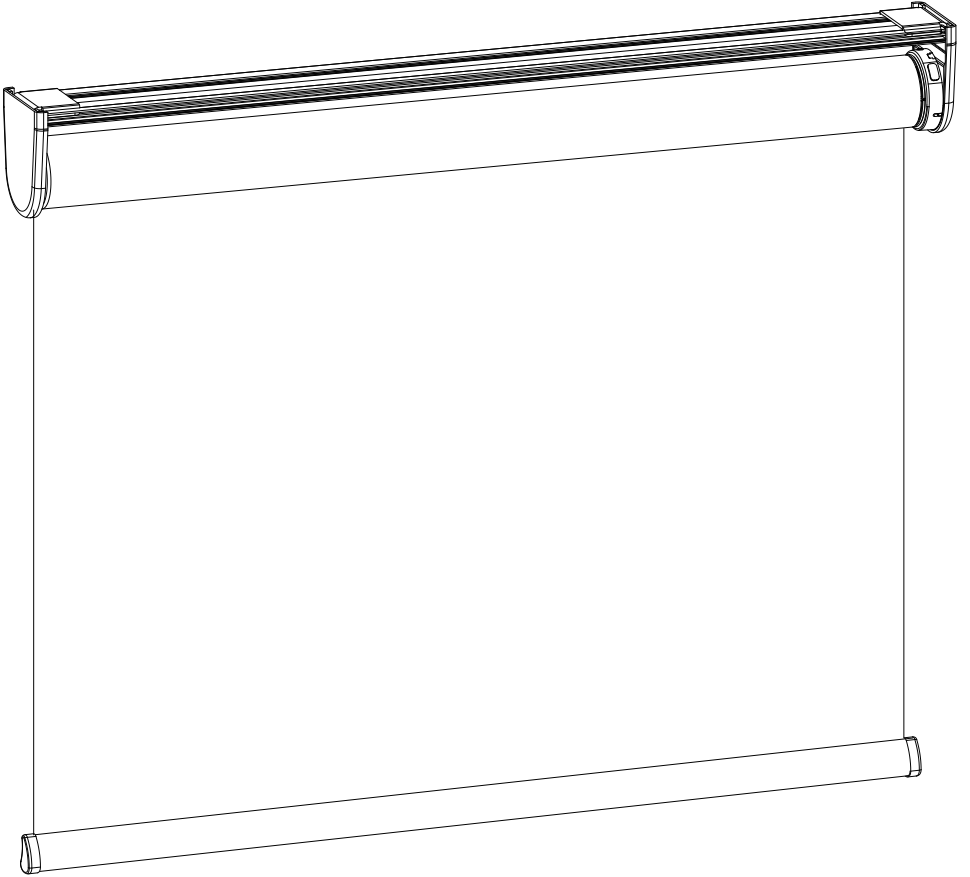

SMARTWINGS

SmartWings Window Covering Advanced Information Product Manual





Engineering Specification	
SmartWings Window Covering Advanced Information Product Manual	
Document No.	Engineering Specification - Z-Wave® Product Line
Version	1.0
Description	<p>This document mainly introduces the new generation SmartWings Window Covering. The content mainly includes its interfaces, accessories, features, specifications, quick start, and software function definition.</p> <p>This device is a security enabled Z-Wave Plus® v2 product that is able to use encrypted Z-Wave Plus v2 messages to communicate to other security S2 enabled Z-Wave Plus v2 products. This device must be used in conjunction with a security enabled Z-Wave controller in order to fully utilize all implemented functions. This product can be operated in any Z-Wave network with other Z-Wave certified devices from other manufacturers. All non-battery operated nodes within the network will act as repeaters regardless of vendor to increase reliability of the network.</p>
Written By	
Date	
Reviewed By	
Date	
Approved By	
Date	

Version	Date	Brief description of changes
1.0	2024.09.25	First revision.

TABLE OF CONTENTS

1. INTERFACES & INSTALLATION.....	1
2. FEATURES & SPECIFICATIONS.....	2
2.1 Structural Characteristics.....	2
2.2 Hardware Characteristics.....	2
2.3 Software Characteristics.....	3
3. PRODUCT QUICK START.....	4
3.1 Important safety information.....	4
3.2 About Z-Wave.....	4
3.3 About SmartStart.....	4
3.4 About Z-Wave Long Range.....	4
3.5 How to add the product into Z-Wave network.....	5
3.6 How to remove the product from Z-Wave network..	6
3.7 How to factory reset.....	7
3.8 Z-Wave DSK Location.....	7
3.9 About Product.....	7
3.10 About Security.....	7
4. SOFTWARE FUNCTION DEFINITION.....	8
4.1 User Behavior Interaction.....	8
4.2 Supported Command Classes.....	8
4.3 Basic Command Class mapping.....	9

4.4 ZWAVEPLUS_INFO.....	9
4.5 Manufacturer Specific.....	10
4.6 Version.....	10
4.7 Association Group Info.....	11
4.8 Multilevel Switch.....	11
4.9 Window Covering.....	12
4.10 Notification.....	13
4.11 Battery.....	13
4.12 Indicator.....	13
4.13 Configuration.....	14

INTERFACES & INSTALLATION

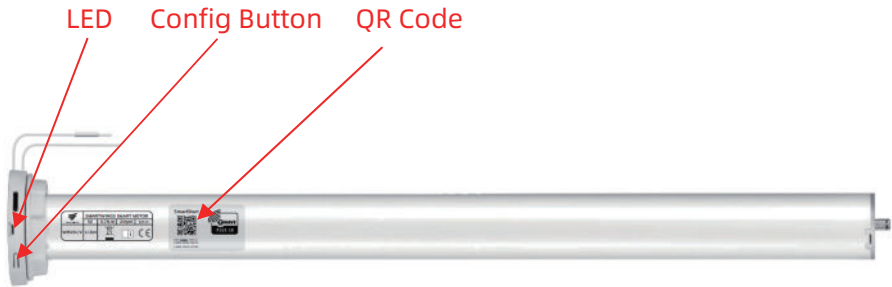

Terminology	Description
LED	Indicates Z-Wave network status
Config Button	Z-Wave network settings or Restore factory settings
QR Code	2D barcode format that can contain large amounts of information in a small square of encoded blocks resembling a random checkerboard pattern. In Z-Wave, it is used to represent the S2 public part of the DSK on a device, as well as additional information needed for the inclusion process

FEATURES & SPECIFICATIONS

2.1 Structural Characteristics

Parameter	Value
Product Identifier	SmartWings Smart Motor
Dimensions	515*55*55mm
Color	White
Usage	For indoor use.
Operating Temperature	32-104°F (0-40°C)
Relative Humidity	Up to 80%

2.2 Hardware Characteristics

Parameter	Value
Z-Wave Module	EFR32ZG23A010F512GM40
Z-Wave TX Power	Max: 14dBm
Z-Wave Antenna Distance	40m (Indoor) /100m (Outdoor)
Indicator Light Color	Red
Power	2200mAh Li-Poly or DC 6.8V~8.4V

2.3 Software Characteristics

Parameter	Value
Wireless Technology	Z-Wave
Certification Type	Z-Wave Plus v2
Z-Wave SDK Version	7.18.08
Z-Wave Library Type	Enhanced 232 Slave
Z-Wave Role Type	ZWAVEPLUS_INFO_REPORT_ROLE_TYPE_SLAVE_SLEEPING_LISTENING (0x07)
Generic Device Type	GENERIC_TYPE_SWITCH_MULTILEVEL (0x11)
Specific Device Type	SPECIFIC_TYPE_CLASS_C_MOTOR_CONTROL (0x07)
SmartStart	Support. After powering on, SmartStart is auto active if it's out of the Z-Wave network
Over The Air (OTA)	Support. Firmware can be updated via RF.
Multichannel Device	No.
Association	Support. Refer to Section 4.7 Association Group Info.
Factory Reset	Support. Refer to Section 3.7 How to factory reset.
Power-down Memory	Support. All command settings will stay unchanged even power down
Group Control	Support. Refer to Section 4.7 Association Group Info
Curtain Status Report	Support. When Manual or Z-Wave Curtain control, send out Basic Report or Switch Multilevel Report via Group 1.
Z-Wave Long Range	Support.

PRODUCT QUICK START

3.1 Important safety information

Please read this Engineering Specification carefully for correct and effective use.

Failure to follow the recommendations set forth by DEYI Limited may be dangerous or cause a violation of the law. The manufacturer, importer, distributor, and/or reseller will not be held responsible for any loss or damage resulting from not following any instruction in this guide or in other materials.

The product is intended for indoor use in dry locations only. Do not use in damp, moist, and /or wet locations.

3.2 About Z-Wave

Z-Wave is the international wireless protocol for communication in the Smart Home.

Z-Wave ensures a reliable communication by reconfirming every message (two-way communication) and every mains powered node can act as a repeater for other nodes (meshed network) in case the receiver is not in direct wireless range of the transmitter.

This device and every other certified Z-Wave device can be used together with any other certified Z-Wave device regardless of brand and origin as long as both are suited for the same frequency range.

If a device supports secure communication it will communicate with other devices secure as long as this device provides the same or a higher level of security. Otherwise it will automatically turn into a lower level of security to maintain backward compatibility.

3.3 About SmartStart

SmartStart enabled products can be added into a Z-Wave network by scanning the Z-Wave QR Code present on the product with a controller providing SmartStart inclusion. No further action is required and the SmartStart product will be added automatically within 10 minutes of being switched on in the network vicinity.

3.4 About Z-Wave Long Range

Z-Wave Long Range device can only support be included via SmartStart.

Extract the DSK from end device and paste it into the DSK Value in PC Controller, make sure the 'Long Range' option is ticked.

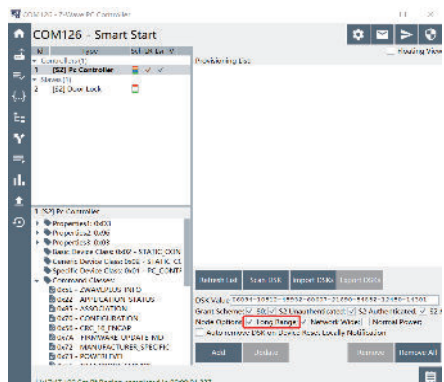

3.5 How to add the product into Z-Wave network

Follow the user guide of hub to enter inclusion mode.

Pairing Method 1:

1. Remove the back cover of the remote.
2. Briefly press the P button until the motor jogs once.
3. Press the UP button until the motor jogs again.
4. Press the P button once more until the motor jogs once.
5. A red LED light will illuminate, indicating the motor is in pairing mode and ready for app connection.

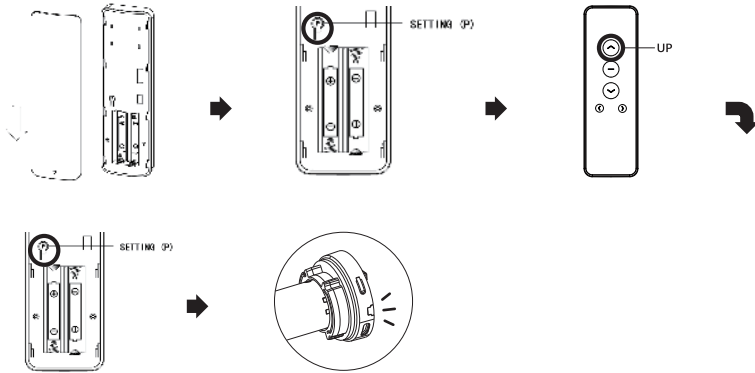

Pairing Method 2:

Press and hold the P1 button on the motor head for 6 seconds. The motor will jog twice, and a red LED light will illuminate, indicating the motor is in pairing mode and ready for app connection.

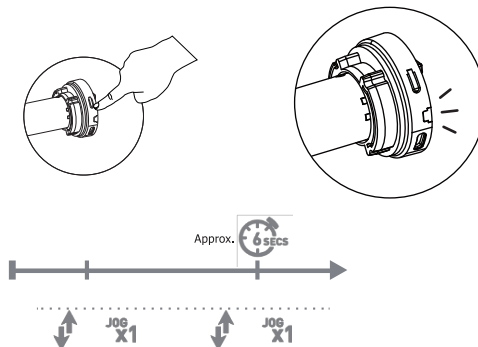

3.6 How to remove the product from Z-Wave network

Follow the user guide of hub to enter exclusion mode.

Pairing Method 1:

1. Remove the back cover of the remote.
2. Briefly press the P button until the motor jogs once.
3. Press the UP button until the motor jogs again.
4. Press the P button once more until the motor jogs once.
5. A red LED light will illuminate, indicating the motor is in pairing mode and ready for app connection.

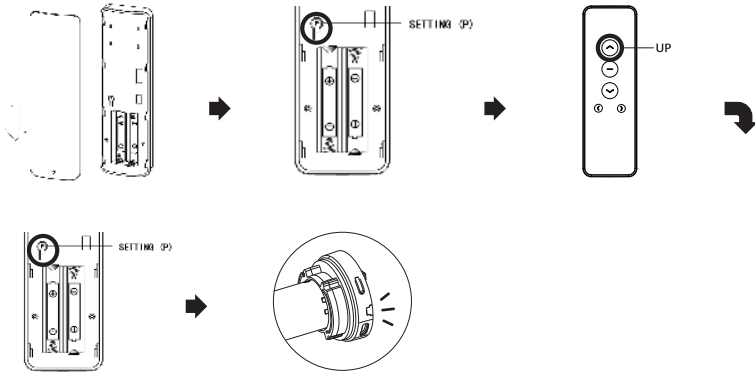

Pairing Method 2:

Press and hold the P1 button on the motor head for 6 seconds. The motor will jog twice, and a red LED light will illuminate, indicating the motor is in pairing mode and ready for app connection.

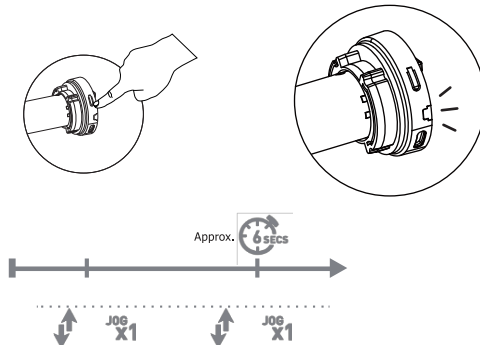

3.7 How to factory reset

1. Please use this procedure only when the network primary controller is missing or otherwise inoperable.
2. Remove the back cover of the remote.
3. Briefly press the P button until the motor jogs once.
4. Press the DOWN button until the motor jogs again.
5. Press the P button once more until the motor jogs once.

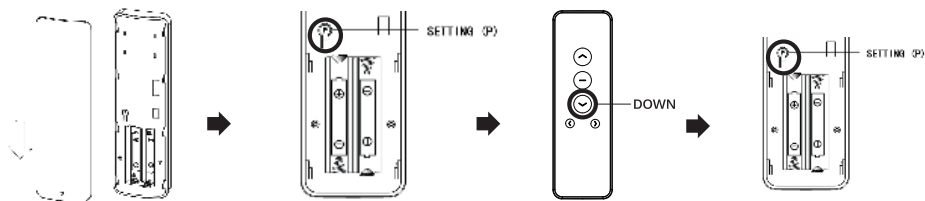

3.8 Z-Wave DSK Location

You can find the QR code on the Curtain.

You may also find the QR Code and DSK card in the individual package of each product.

Please do not remove or damage them.

3.9 About Product

This product can be operated in any Z-Wave network with other Z-Wave certified devices from other manufacturers. All mains operated nodes within the network will act as repeaters regardless of vendor to increase reliability of the network.

3.10 About Security

This device is a security enabled Z-Wave Plus product that is able to use encrypted Z-Wave Plus messages to communicate to other security enabled Z-Wave Plus products. S2 Security Enabled Controller is required to operate the device.

SOFTWARE FUNCTION DEFINITION

4.1 User Behavior Interaction

User behavior	Out of the Z-Wave network	In the Z-Wave network
Power on	Send Inclusion Requests for SmartStart	NA
Inclusion network	Inclusion network Press and hold the Config Button more than 6s, enter "Include mode"	NA
Exclusion network	NA	Press and hold the Config Button more than 6s, enter "Exclusion mode"
Factory reset	NA	Press and hold the Config Button more than 14s, then release.

4.2 Supported Command Classes

ENDPOINT ROOT:

Command Classes	Version	Required Security Class
COMMAND_CLASS_ZWAVEPLUS_INFO_V2	2	None
COMMAND_CLASS_TRANSPORT_SERVICE_V2	2	None
COMMAND_CLASS_SECURITY_2_V1	1	None
COMMAND_CLASS_SUPERVISION_V1	1	None
COMMAND_CLASS_APPLICATION_STATUS_V1	1	None
COMMAND_CLASS_WINDOW_COVERING_V1	1	Highest granted Security Class
COMMAND_CLASS_SWITCH_MULTILEVEL_V4	4	Highest granted Security Class
COMMAND_CLASS_CONFIGURATION_V4	4	Highest granted Security Class
COMMAND_CLASS_ASSOCIATION_V2	2	Highest granted Security Class
COMMAND_CLASS_ASSOCIATION_GRP_INFO_V1	1	Highest granted Security Class
COMMAND_CLASS_VERSION_V3	3	Highest granted Security Class

SOFTWARE FUNCTION DEFINITION

COMMAND_CLASS_MANUFACTURER_SPECIFIC_V2	2	Highest granted Security Class
COMMAND_CLASS_DEVICE_RESET_LOCALLY_V1	1	Highest granted Security Class
COMMAND_CLASS_BATTERY_V1	1	Highest granted Security Class
COMMAND_CLASS_POWERLEVEL_V1	1	Highest granted Security Class
COMMAND_CLASS_FIRMWARE_UPDATE_MD_V5	5	Highest granted Security Class
COMMAND_CLASS_MULTI_CHANNEL_ASSOCIATION_V3	3	Highest granted Security Class
COMMAND_CLASS_INDICATOR_V3	3	Highest granted Security Class

4.3 Basic Command Class mapping

Basic Command maps to Switch Multilevel Command Class, as shown below.

Command	Value	Mapped	Value
Basic Set	0x00	Multilevel Switch Set	0x00
	0xFF		0xFF
	0x01-0x63		0x01-0x63
Basic Get/Report		Multilevel Switch Get/Report	

4.4 ZWAVEPLUS_INFO

The Command is used to differentiate between Z-Wave Plus v2, Z-Wave for IP and Z-Wave devices. This command provides additional information about the Z-Wave Plus v2 device in question.

Parameter	Value
Z-Wave Plus Version	0x02
Role Type	0x07 (ZWAVEPLUS_INFO_REPORT_ROLE_TYPE_SLAVE_SLEEPING_LISTENING)
Node Type	0x00 (ZWAVEPLUS_INFO_REPORT_NODE_TYPE_ZWAVEPLUS_NODE)
Installer Icon Type	0x1A00 (ICON_TYPE_GENERIC_WINDOW_COVERING_POSITION_ENDPOINT_AWARE)
User Icon Type	0x1A00 (ICON_TYPE_GENERIC_WINDOW_COVERING_POSITION_ENDPOINT_AWARE)

4.5 Manufacturer Specific

The Command is used to advertise manufacturer specific information.

Parameter	Value
Manufacturer ID 1	0x04
Manufacturer ID 2	0x5A
Product Type ID 1	0x00
Product Type ID 2	0x04
Product ID 1	0x05
Product ID 2	0x0B

4.6 Version

The Command may be used to obtain the Z-Wave library type, the Z-Wave protocol version used by the application, the individual command class versions used by the application.

Parameter	Value
Z-Wave Protocol Library Type	0x03
Z-Wave Protocol Version	0x07
Z-Wave Protocol Sub Version	0x12
Firmware 0 Version	Z-Wave Chip Firmware Version Major
Firmware 0 Sub Version	Z-Wave Chip Firmware Version Minor
Hardware Version	0x01
Number of firmware targets	0x01
Firmware 1 Versione	MCU Chip Firmware Version Majore
Firmware 1 Sub Versione	MCU Chip Firmware Version Minore

4.7 Association Group Info

The Command is used to manage associations to Node ID destinations.
Endpoint Root:

ID	Name	Count	Profile	Function
1	Lifeline	5	General: Lifeline (0x0001)	Basic Report(0x2003): Issued when motor status changed (Configurable by param 11). Switch Multilevel Report(0x2603): Issued when motor status changed (Configurable by param 11). Window Covering Report(0x6A04): Issued when motor status changed(Configurable by param 11). Notification Report(0x7105): Issuedwhen ACmains changed or battery becomes low. Device Reset Locally Notification (0x5A01): Issued when Factory Reset is performed. Battery Report(0x8003): Issued periodically to report the current battery level; Issued when battery becomes low. Indicator Report(0x8703): Issued when indicator set received
2	On/Off Control	5	Control: KEY01 (0x2001)	Basic Set(0x2001): Issued when endpoint 1 motor status changed
3	Multilevel Set	5	Control: KEY02 (0x2002)	Switch Multilevel Set(0x2601): Issued when endpoint 1 motor status changed
4	Multilevel Start/Stop	5	Control: KEY03 (0x2003)	Switch Multilevel Start Level Change(0x2604)/ Switch Multilevel Stop Level Change(0x2605): Issued when endpoint 1 motor status changed

4.8 Multilevel Switch

The Command is used to control window curtain devices.

1. Switch Multilevel Set

This device can accept Switch Multilevel Set Command which value is either (0x00) Bottom or Top (0x63) or (0x01-0x62) the position between TOP and Bottom. Other value (0x64-0xFE) is not acceptable.

2. Switch Multilevel Get

When the Curtain receives Switch Multilevel Get Command, it will send Switch Multilevel Report Command to report the position of the Curtain. When the report value is 0x00, that mean the shutter is at the Bottom, if the report value is 0x63 that mean the shutter is at the top, any other value between 0x01~0x62 imply shutter at the position between top and bottom.

3. Switch Multilevel Start Level Change

This is the command which user can move the Curtain up to the top or down to the bottom.

If Up/Down Bit=0x00 Curtain move up.

If Up/Down Bit=0x01 Curtain move down.

Note:

The Curtain will Ignore Start Level、 Start Level、 Dimming Duration、 Inc/Dec、 Step size.

The Curtain cannot control the speed of motor.

It may have some distance error caused by motor start up time.

4. Switch Multilevel Stop Level Change

When the Curtain receive Switch Multilevel Stop Level Change Command, it will stop the motor.

4.9 Window Covering

The Command is used to control window curtain devices.

1. Support Parameter ID = 13(out bottom)

2. Support Value Range = 0x00 - 0x63

3. Window Covering Supported Report Command:

1) Number of Parameter mask bytes = 2

2) Parameter Mask 1 = 0x00

3) Parameter Mask 2 = 0x20 (out bottom)

4. Window Covering Set

This device can accept Window Covering Set Command which value is either (0x00) Bottom or Top (0x63) or (0x01-0x62) the position between TOP and Bottom. Other value (0x64-0xFE) is not acceptable.

5. Window Covering Get

When the Curtain receives Window Covering Get Command, it will send Window Covering Report Command to report the position of the Curtain. When the report value is 0x00, that mean the shutter is at the Bottom, if the report value is 0x63 that mean the shutter is at the top, any other value between 0x01~0x62 imply shutter at the position between top and bottom.

6. Window Covering Start Level Change

This is the command which user can move the Curtain up to the top or down to the bottom.

If Up/Down Bit=0x00 Curtain move up.

If Up/Down Bit=0x01 Curtain move down.

Note:

The Curtain will Ignore Duration.

7. Window Covering Stop Level Change

When the Curtain receive Window Covering Stop Level Change Command, it will stop the motor.

4.10 Notification

The Command is used to advertise events or states, such.

Notification Type = Power Management (0x08)

Table 4-10-1:

Description	Notification Event	Alarm type	Alarm Level	Parameters
AC mains disconnected	0x02	0x00	0x00	0x03
AC mains re-connected	0x03	0x00	0x00	0x02
Charge battery soon	0x0E	0x00	0x00	
Charge battery now	0x0F	0x00	0x00	

4.11 Battery

The Command is used to request and report battery levels for a given device.

1. If send Battery Get to the device, it will issue Battery Report with current battery level to the requester.
2. If waked up, it will detect battery level, and issue Battery Report (Value=0xFF) via Lifeline when battery level is less than 10%, refer to Configuration Parameter 8.
3. If the battery value change exceeds 5%, the battery report will be sent, refer to Configuration Parameter 10.
4. Support timed battery report, refer to Configuration Parameter 9.

4.12 Indicator

The Command is used to help end users to monitor the operation or condition of the application provided by a supporting node.

Indicator ID		Property ID	
Node Identify	0x50	On Off Period	0x03
		On Off Cycles	0x04
		On time within an On/Off period	0x05

4.13 Configuration

The Command allows product specific configuration parameters to be changed.

Note: No Bulk Support equals to True. It will return an Application Rejected Request Command when receiving Configuration Bulk Set or Get (if received without Supervision encapsulation). It will reset all its configuration parameters if either manually reset to factory default or receives a Configuration Default Reset Command. It will NOT modify or reset any configuration parameter when being included or excluded of a Z-Wave network.

Parameter 1:

This type of motor does not support this function, don't need to test it.

Parameter	0x01 (1)			
Name	Enable manual pull-start			
Info	Enable manual pull-start			
Properties	Size	1	Min Value	0
	Format	Enumerated	Max Value	1
	Read-only	False	Default Value	1
	Altering capabilities	False	Advanced	False
Description	This parameter can be used to set the manual pull-start of the motor.			
	Value	Function		
	0	Close		
	1	Open		

SOFTWARE FUNCTION DEFINITION

Parameter 2:

Parameter	0x02 (2)			
Name	Set motor direction			
Info	Set motor direction			
Properties	Size	1	Min Value	1
	Format	Enumerated	Max Value	2
	Read-only	False	Default Value	1
	Altering capabilities	False	Advanced	False
Description	This parameter can be used to set the motor rotation direction.			
	Value	Function		
	1	forward.		
	2	Reverse		

Parameter 3:

This type of motor does not support this function, don't need to test it.

Parameter	0x03 (3)			
Name	Manually set open borders			
Info	Manually set open borders			
Properties	Size	1	Min Value	0
	Format	Enumerated	Max Value	1
	Read-only	False	Default Value	0
	Altering capabilities	False	Advanced	False
Description	Manually set / cancel open borders.			
	Value	Function		
	1	Cancel manually open the border.		
	2	Manually set the open boundary.		

SOFTWARE FUNCTION DEFINITION

Parameter 4:

This type of motor does not support this function, don't need to test it.

Parameter	0x04 (4)			
Name	Manually set close borders			
Info	Manually set close borders			
Properties	Size	1	Min Value	0
	Format	Enumerated	Max Value	1
	Read-only	False	Default Value	0
	Altering capabilities	False	Advanced	False
Description	Manually set / cancel close borders.			
	Value	Function		
	0	Cancel manually close the border.		
	1	Manually set the close boundary		

Parameter 5:

Parameter	0x05 (5)			
Name	Set motor status			
Info	Set motor status			
Properties	Size	1	Min Value	1
	Format	Enumerated	Max Value	3
	Read-only	False	Default Value	3
	Altering capabilities	False	Advanced	False
Description	Set motor status.			
	Value	Function		
	1	Open(UP).		
	2	Close(DOWN).		
	3	Stop(STOP).		

SOFTWARE FUNCTION DEFINITION

Parameter 6:

Parameter	0x06 (6)			
Name	Calibration the travel point			
Info	Calibration the travel point			
Properties	Size	1	Min Value	1
	Format	Enumerated	Max Value	3
	Read-only	False	Default Value	1
	Altering capabilities	False	Advanced	False
Description	Calibration the travel point.			
	Value	Function		
	1	Up travel point.		
	2	Down travel point.		
	3	Third travel point.		

Parameter 7:

Parameter	0x07 (7)			
Name	Delete the travel point			
Info	Delete the travel point			
Properties	Size	1	Min Value	0
	Format	Enumerated	Max Value	3
	Read-only	False	Default Value	0
	Altering capabilities	False	Advanced	False
Description	Delete the travel point.			
	Value	Function		
	0	Delete All travel.		
	1	Delete Up travel.		
	2	Delete Down travel.		
	3	Delete Third travel.		

SOFTWARE FUNCTION DEFINITION

Parameter 8:

Parameter	0x08 (8)			
Name	Low battery level alarm threshold			
Info	Low battery level alarm threshold			
Properties	Size	1	Min Value	0
	Format	Enumerated	Max Value	50
	Read-only	False	Default Value	10
	Altering capabilities	False	Advanced	False
Description	Configure low battery report threshold, sends low battery report via battery report when battery level drops under setting. Unit %.			
	Value	Function		
	0-50	0% to 50%.		

Parameter 9:

Parameter	0x09 (9)			
Name	Battery auto report interval time			
Info	Battery auto report interval time			
Properties	Size	4	Min Value	0
	Format	Enumerated	Max Value	2678400
	Read-only	False	Default Value	3600
	Altering capabilities	False	Advanced	False
Description	Interval time set in seconds. Battery Report will be sent when timeout.			
	Value	Function		
	0	Disable.		
	1-2678400	1 to 2678400s.		

SOFTWARE FUNCTION DEFINITION

Parameter 10:

Parameter	0x0A (10)			
Name	Battery change report threshold			
Info	Battery change report threshold			
Properties	Size	1	Min Value	0
	Format	Enumerated	Max Value	50
	Read-only	False	Default Value	5
	Altering capabilities	False	Advanced	False
Description	Battery change auto report threshold.			
	Value	Function		
	0	Disabled.		
	1-50	1% to 50%.		

Parameter 11:

Parameter	0x0B (11)			
Name	Curtain status report command setting			
Info	Curtain status report command setting			
Properties	Size	1	Min Value	0
	Format	Enumerated	Max Value	7
	Read-only	False	Default Value	6
	Altering capabilities	False	Advanced	False
Description	Which report will be sent to lifeline group when the Curtain status is changed.			
	Value	Function		
	0	Send nothing.		
	1	Send Basic Report.		
	2	Send Switch Multilevel Report		
	3	Send Window Covering Report		
	4	Send Basic Report and Switch Multilevel Report.		
	5	Send Basic Report and Window Covering Report.		
	6	Send Switch Multilevel Report and Window Covering Report.		
7	Send Basic Report and Switch Multilevel Report and Window Covering Report.			



SMARTWINGS

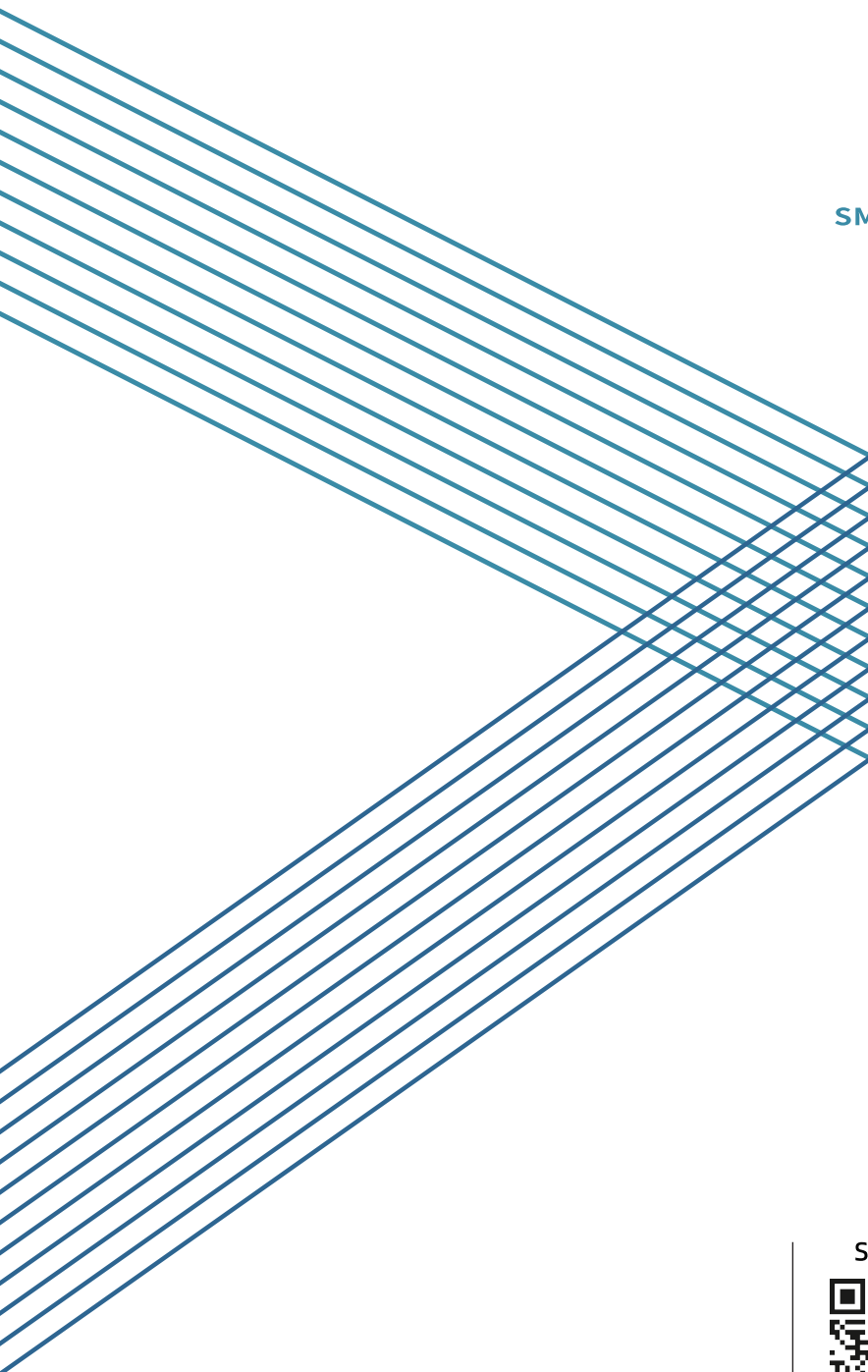

T +1 877 762 7861
www.smartwingshome.com
support@smartwingshome.com

Social Media

